

General information

Download technical specification

[Technical Specification](#)

Model selection

Different Gateway models are available depending on the periphery availability and type.

Model	Cellular Network				GNSS	Internal memory	
	GPRS	3G	LTE 4G	5G		Flash 64MB	NAND 512MB
AG-743						√	√
AG-743-LT-EU	√		√		√	√	√
AG-743-LT-GL	√	√	√		√	√	√

Hardware informations

The Gateway is made on one PCB, which is fitted to the aluminum housing. The housing is made of a thick, strong aluminum profile with two end plates also made from aluminum. The surface of the housing is finished by anodizing.

At the bottom of the housing there are slots through which DIN rail clamp or any other clamp can be mounted by t-nuts.

Top view dimensions

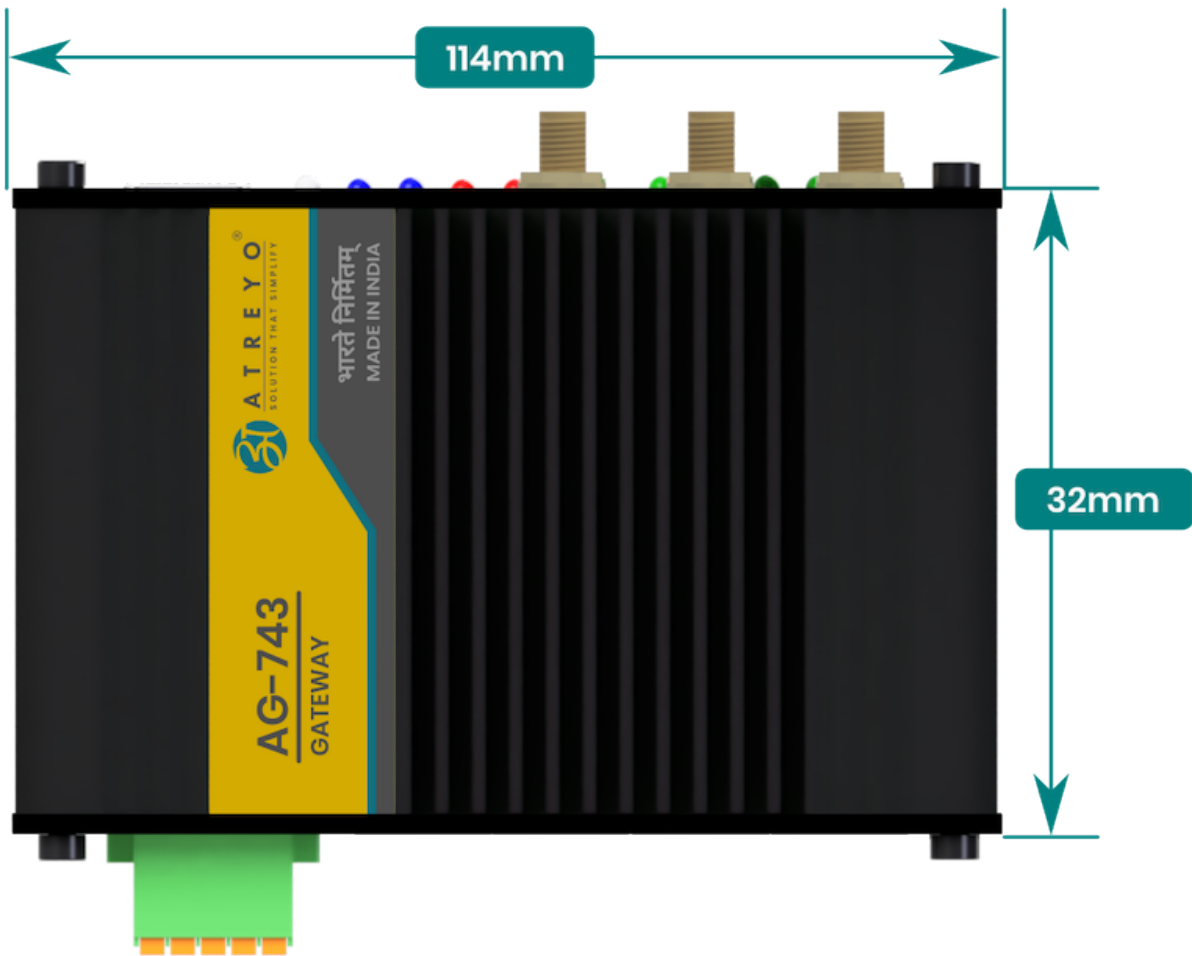

Side view dimensions

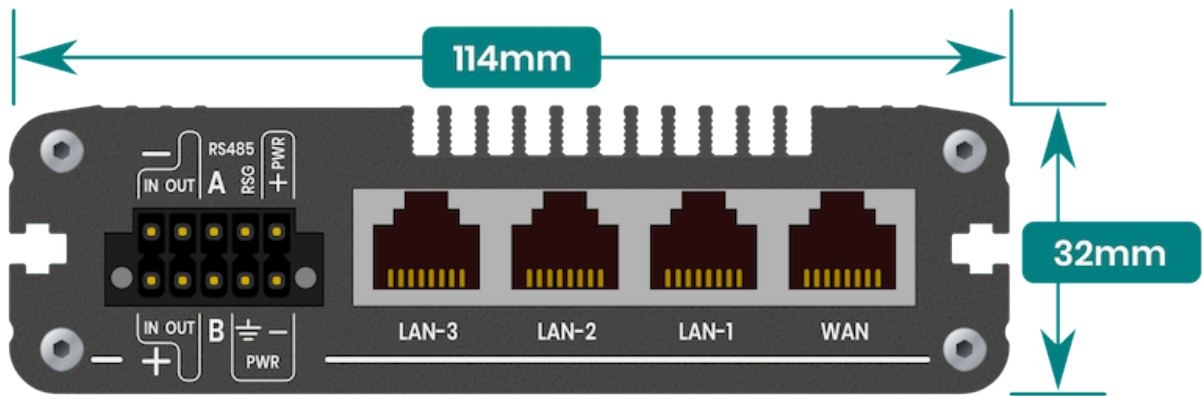

Connectors

Top view connectors and indicators

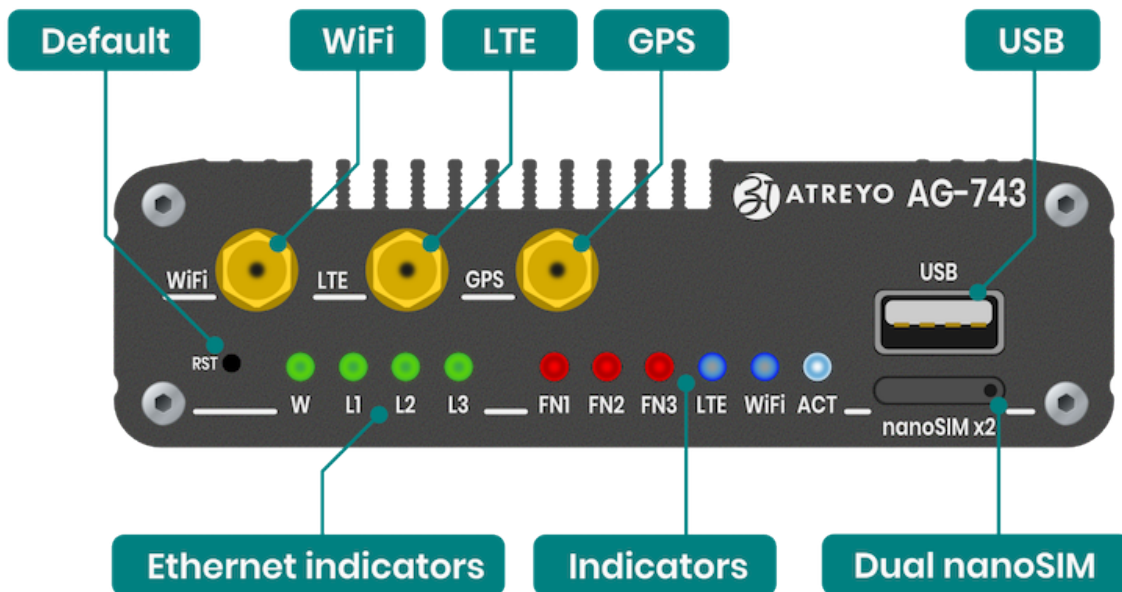

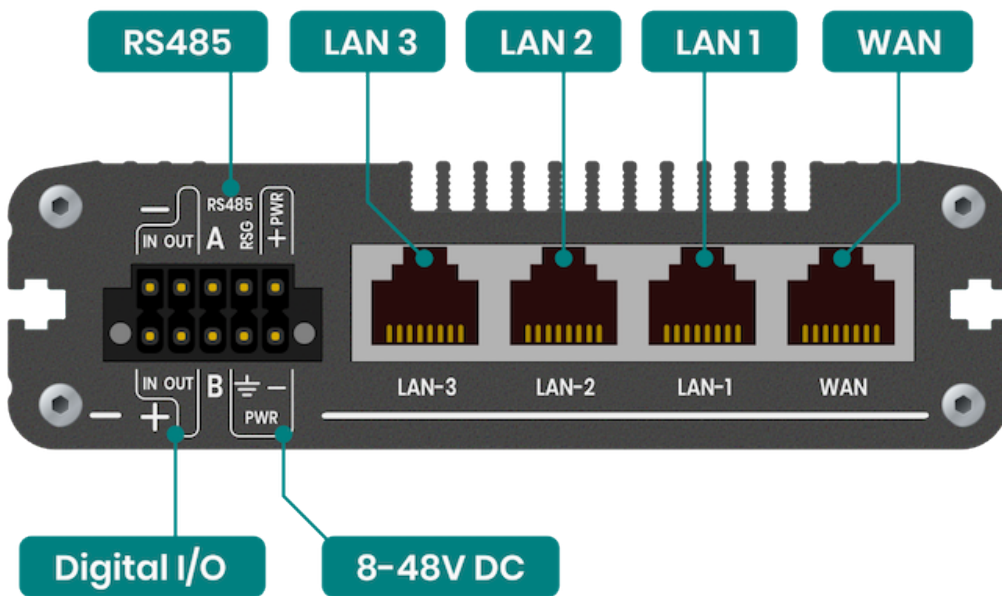

Block diagram

For a better understanding of the operation of the gateway, refer to the block diagram. Non-essential components have been omitted. Developers who program peripherals such as GPIOs, serial etc. will find information about them in the sections dedicated to such peripherals.

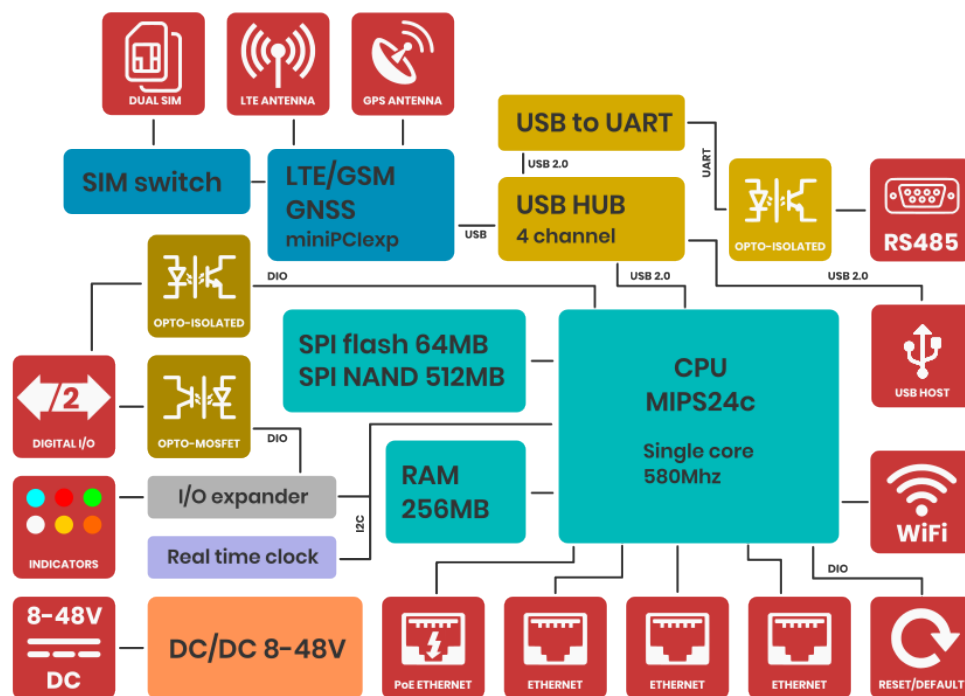

Power supply

The Gateway power supply range is 8-48V DC. You need to connect the gate according to the inscriptions at the main connector. The Gateway is protected against reverse power connection. If the polarity is reversed, the Gateway will not start.

PoE

The Gateway can also be powered via PoE in the range of input power supply using unused pairs of wires in the LAN cable. Below is the pinout of the RJ45 socket.

Pin number	Function	Comment
1	RX+	Data
2	RX-	Data
3	TX+	Data
4	DC+	Power supply positive
5	DC+	Power supply positive
6	TX-	Data
7	DC-	Power supply negative
8	DC-	Power supply negative

LTE 4G modem

Generally, the Gateway supports all versions of Quectel or Telit MiniPCI express modems. However, you can use a third-party modem, as long as the signal outputs are compatible with those of the Quectel company. For use your LTE module, select model without LTE module installed. You also need to pay attention to the power supply to the LTE module should be 3.3V.

Mobile network signal strength is also displayed on 4 LED indicators.

MiniPCI express pinout

Below is the description of the PCI express pinout used in the AG-702. Before installing anything other than the EC200U or EG25, be sure to check the pinout for compatibility. The LTE model is connected via a USB data bus.



1	WAKE	2	3.3V
3	NC	4	GND
5	NC	6	NC
7	NC	8	SIM-VDD
9	GND	10	SIM-IO
11	NC	12	SIM-CLK
13	NC	14	SIM-RST
15	GND	16	NC
17	NC	18	GND
19	NC	20	FLIGHT RESET
21	GND	22	NC
23	NC	24	NC
25	NC	26	GND
27	GND	28	NC
29	GND	30	NC
31	NC	32	NC
33	NC	34	GND
35	GND	36	USB-DM
37	GND	38	USB-DP
39	3.3V	40	GND
41	3.3V	42	LED
43	GND	44	SIM-DET
45	NC	46	NC
47	NC	48	NC
49	NC	50	GND
51	NC	52	3.3V

GNSS

Device has onboard LTE modem along with GNSS function. In order to receive the GNSS signal, an antenna is required. There are two types of GNSS antennas: active gnss antenna and passive gnss antenna. The AG-743 supports both types of antennas, but in order for the active antenna to work properly, it is necessary to start powering the active antenna. To do this, you need to go to **System > Custom Commands** and select the command **Turn GPS antenna to active mode**.

Also on this page, you can test whether the GNSS is working properly. To do so, you need to click **Activate GPS on ttyUSB7** and then **Show GPS location**.

Ethernet

The gateway has four RJ45 ethernet ports with LED indicators on front. The speed of each is 100Mbps. Three are configured as LAN and one as WAN. WAN supports PoE on free RJ45 pairs.

WiFi

The gateway has WiFi 2.4Ghz. By default, the WiFi is set as a hotspot and shares internet from Ethernet and from LTE via WiFi.

WiFi is used for remote configuration of the device. It does not have a long range, so it may not fully meet some requirements.

RTC

The gateway has a built-in RTC with superCAP backup power.

Serial Interface - RS485

The Gateway has one serial RS485 port. It is optically isolated. The baudrate range for RS485 port is 600 bps to 460800 bps. Note that with a longer cable, the maximum speed may drop. It is recommended to use special cables designed for RS485. The port is protected by high-power TVS diodes and GDT against electrical surges.

Digital I/O

The Gateway has one digital input and one digital output.

Digital input

The digital input is completely independent optically isolated input that accept an input signal level of up to 30V DC. It can be connected either with a common plus or minus (NPN/PNP). Can be controlled with open collector. They require to be powered. The range of the signal considered as a logical 1 is from 3.5V to the maximum input voltage.

Digital output

The digital output is realized on a opto-mosfet whose load capacity is 800mA. The maximum voltage is 40V AC and 40DC. The output is only in normal open format (NO).

LED indicators

The AG-743 gateway has 10 indicators on the front panel. By default, they are programmed to perform certain functions, but they are all controlled by the processor and knowing the OpenWRT system well, change their functions. The LAN indicators are also located on the front panel.

Revision #6

Created 2025-08-17 12:28:43 UTC by Yogesh

Updated 2025-10-17 10:00:25 UTC by Yogesh