

AIC-550

The AIC-550 is multipurpose Industrial Computer with inbuilt M.2 SSD storage for data. It is based on quad core ARM Cortex-A55 64bit processor. The computer has 4G LTE/GPRS or 5G cellular modem and optional WiFi or Bluetooth.

This computer in addition to industrial use, due audio out it can be used as a media and video controller in vehicles and at bus stops, railway stations and as information kiosk controller. It also has a USB type-C port for debugging.

- [General information](#)
- [Safety information](#)

General information

Download technical specification

[Technical Specification](#)

Model Selection

Atreyo produces different versions of the AIC-550. Below is a table of model selection. If there is no interface listed in the table, it means that it slips in all versions.

Variant	Internal storage			RAM		SSD		Cellular Network	
	16B	32GB	64GB	4GB	8GB	128GB	480GB	GPRS	LTE
AIC-550		√		√					

Hardware

The Computer is made on one PCB, which is fitted to the aluminum housing. The housing is made of a thick, strong aluminum profile with two end plates also made from aluminum. The surface of the housing is finished by anodizing.

At the side of the housing there are slots through which DIN rail clamp or any other clamp can be mounted by t-nuts.

Top view

Side view

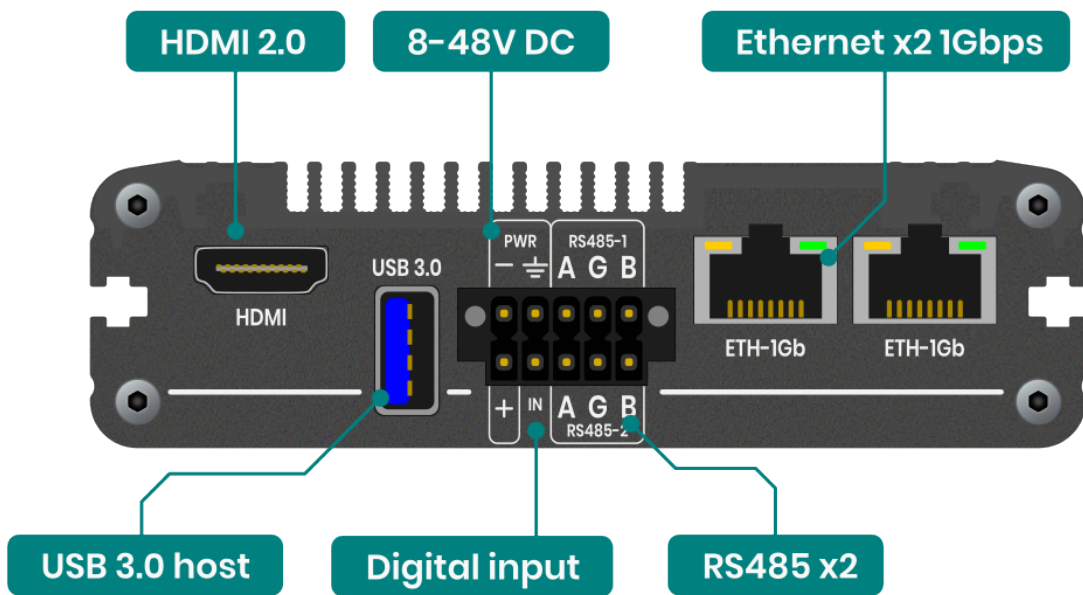
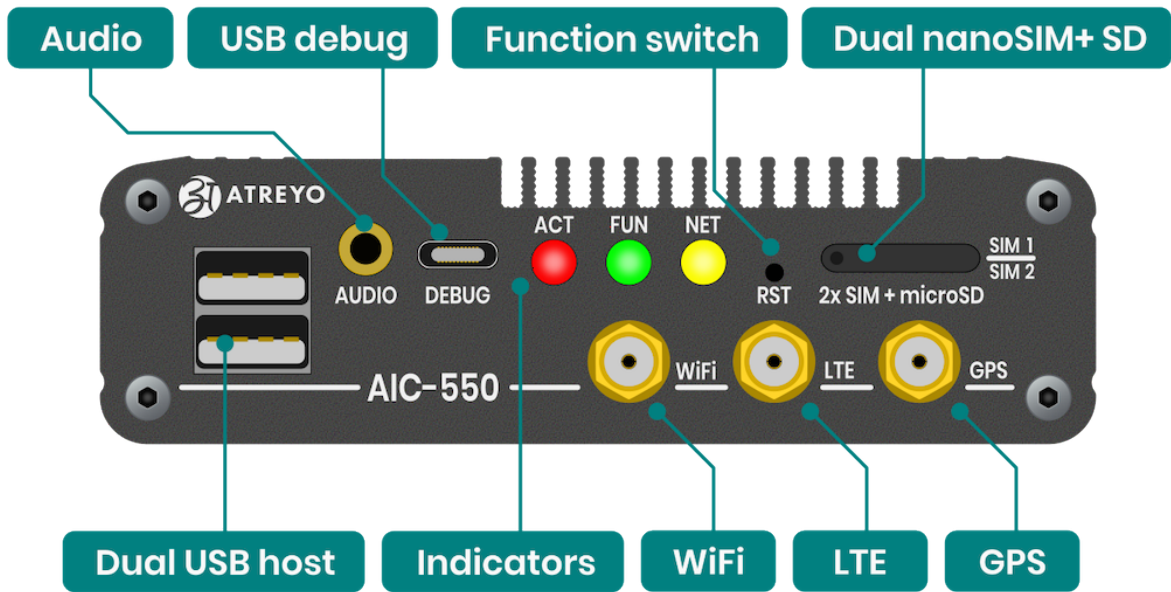

Block Diagram

For a better understanding of the operation of the computer, refer to the posted block diagram. Non-essential components have been omitted. Developers who program peripherals such as GPIOs, serial etc. will find information about them in the sections dedicated to such peripherals.

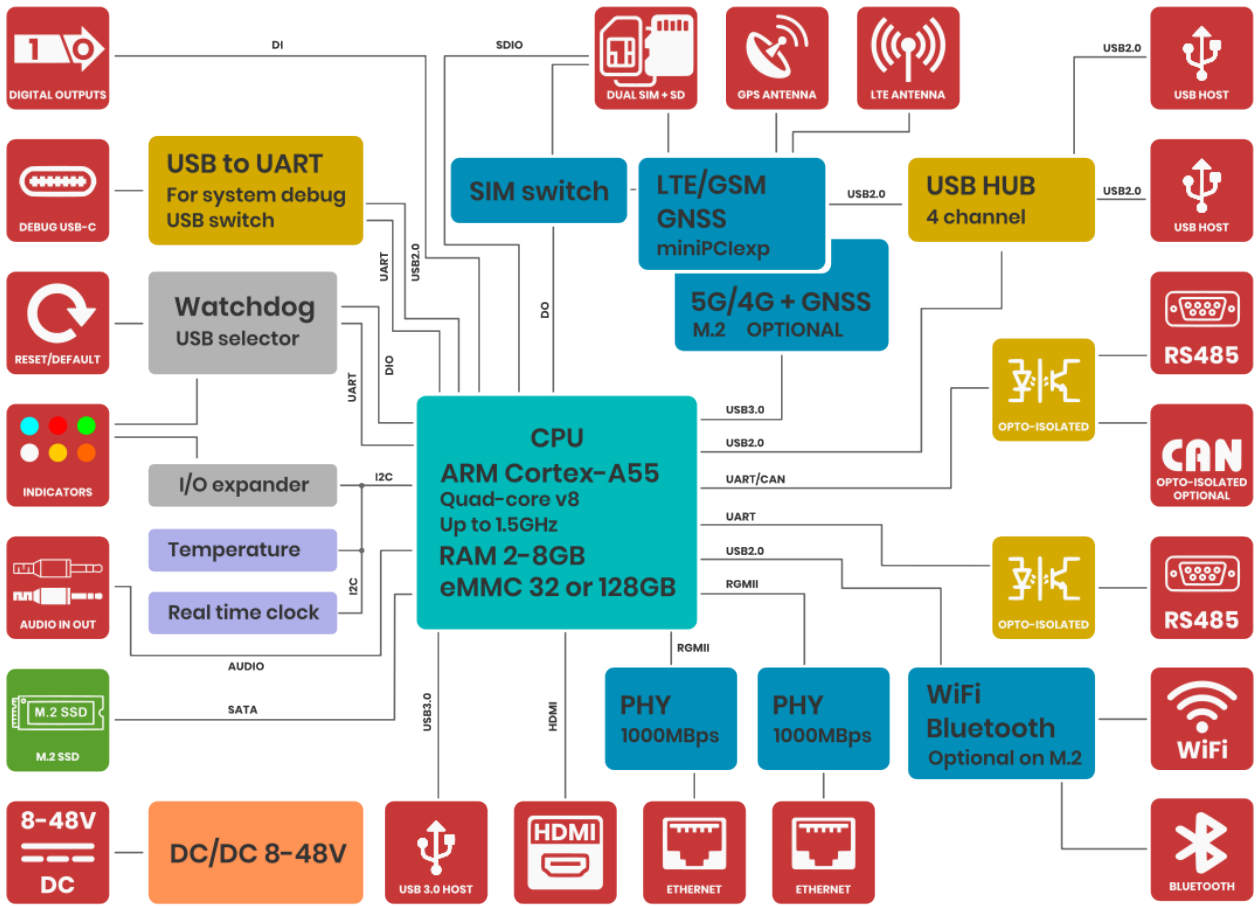

Safety information

Operating environment

- The device is designed to be installed in clean, dust-free and insect-free places
- Operating temperature: -25 ~ 65°C (-13 ~ 149°F).
- Humidity range is 10% to 95% (non-condensing). Use the device in a dry environment.
- Away from heat sources and direct sunlight.
- It must not be exposed to acid fumes, salts and other chemicals.
- The device must not be used in places where there is a risk of gas explosion.

Use in inappropriate conditions may damage the device or shorten its life.

Electrical and power supply safety

- The device is powered with a voltage in the range of 8-36V. Voltage up to 24V is considered safe. Be especially careful when supplying them with higher voltages.
- Use only approved accessories
- Use the supplied power adapter or a good quality certified power adapter with the correct supply voltage range and sufficient power.
- Only use approved accessories like antenna etc.

Only a person with qualification and appropriate knowledge should install the device.

Malfunctioning and damaged device

- Do not disassemble the device.
- Only qualified personnel must service or repair the device or its accessories.
- If water or other liquid has got into the device, or if it looks mechanically damaged, do not connect the device, but take it to an authorized service center.

Radio frequency exposure

This device has been designed and manufactured not to exceed radio frequency energy emission limits set by regulatory agencies. To comply with RF exposure guidelines, the device must be used at least 20 cm away from a person's body. Failure to follow these instructions may result in exceeding the applicable RF exposure limits. This only applies to models with a built-in LTE modem.

What to do and what not to do

- You are solely responsible for the use of the device and any consequences of its use.
- Do not store or use the device in harsh environments such as dust, gases, oils, chemical vapors and damp places.
- Do not throw the device and its accessories. Handle with care.
- The device heats up during operation. Ensure proper ventilation.
- If you need to dispose of your device, check your local regulations for recycling and disposal of electronics.
- Route power, Ethernet, and antenna cables properly so that they cannot be accidentally pulled out.
- The device should be used and kept away from small children.