

ALWG-1638

Atreyo LoRaWAN® gateway is powered with an ARM Cortex-A7 processor with ease of outdoor installation and IP67-rated environment-resistant aluminum enclosure to support your smart city, smart industry, professional LoraWAN® network applications, and industrial control systems. It also has an emergency Supercap backup supply for the last message. The gateway's dual SIMs ensure network connectivity redundancy.

ALWG-1638 has inbuild:

- ChirpStack MQTT forwarder
- ChirpStack Network Server
- ChirpStack Application Server
- Node-RED

Please read the user manual carefully before starting and proceeding with the device.

Also, read the product [safety information](#).

- [General Information](#)
- [Configuration Manual](#)
- [Chirpstack LNS](#)
- [Node-RED](#)
- [Use cases/ Examples](#)
- [Firmware releases](#)
- [Safety information](#)

General Information

Download technical specification

[Technical Specification](#)

Model selection

Different LoRaWAN Gateway models are available depending on frequency band/region and on the periphery availability and it's type.

Model	Lora frequency / Country			Cellular		
	IN	US	EU	IN	EU	GL
ALWG-1638-IN-LT-IN	√			√		
ALWG-1638-IN-LT-EU	√				√	
ALWG-1638-IN-LT-GL	√					√

- **ALWG-1638-IN-LT-IN** comes with IN865 region and 4G LTE modem certified for India region.
- **ALWG-1638-IN-LT-EU** comes with IN865 region and 4G LTE modem certified for Europe region.
- **ALWG-1638-IN-LT-GL** comes with IN865 region and 4G LTE modem certified all over the world.

Models with other configurations are available by special order. See “Technical Specification” for how to select the correct model.

Hardware information

The Gateway is made from aluminium back and UV resistant PC front. It is IP67.

Front view dimensions



Top/Bottom view dimensions

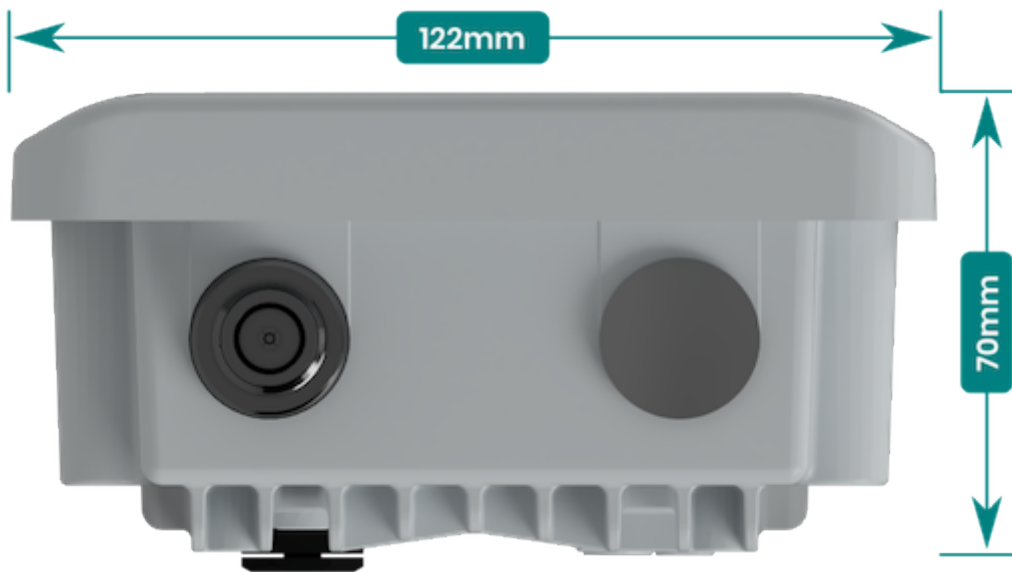

Top connectors

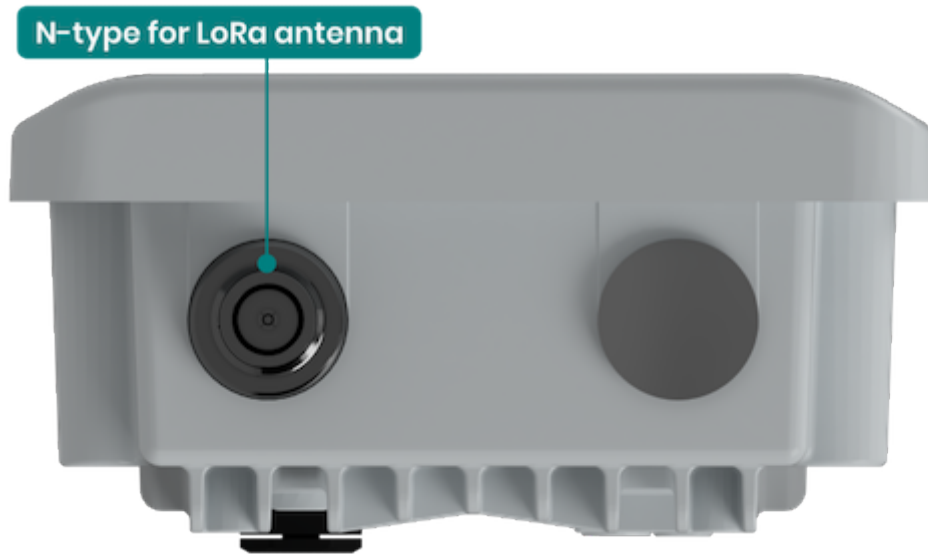

Bottom connectors

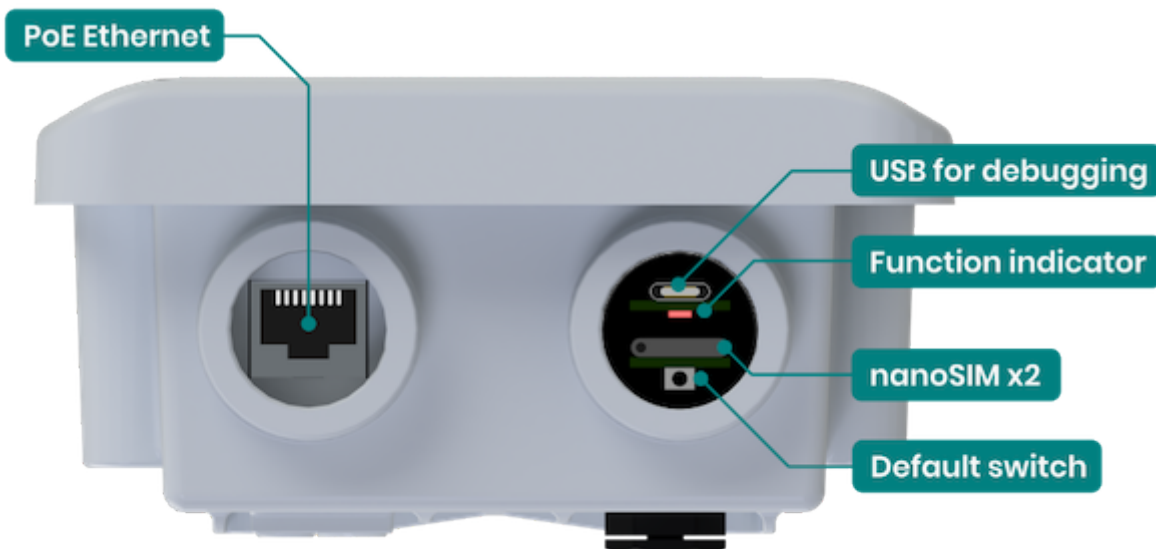

Power Supply

Connect the gateway to the power supply as referenced in the below diagram, and use the standard input/output-rated power adapter as per safety guidance.

The Gateway is to be powered via isolated **PoE** in the range of **37-57V DC**.

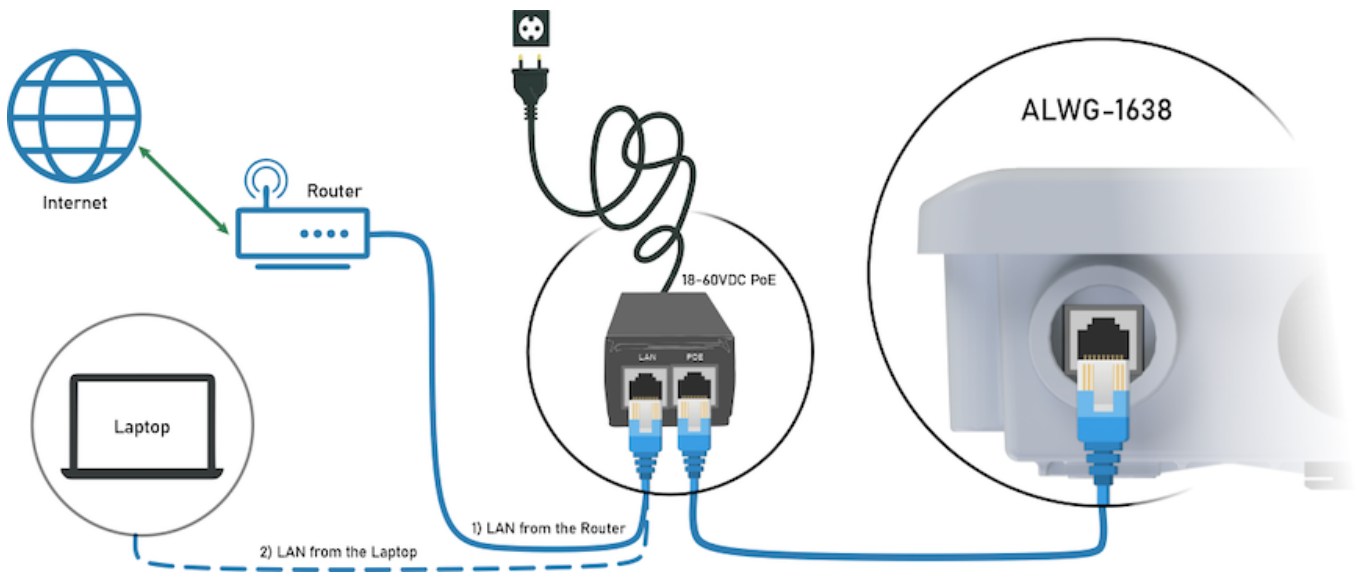

The above connection diagram shows two ways to connect the gateway to the network and power supply.

PoE Ethernet pinout

Below is the PoE Ethernet pinout for reference.

PIN number	Function	Remark
1	RX+	Data
2	RX-	Data
3	TX+	Data
4	DC+	Power supply positive
5	DC+	Power supply positive
6	TX-	Data
7	DC-	Power supply negative
8	DC-	Power supply negative

Block diagram

A block diagram of the device is shown below.

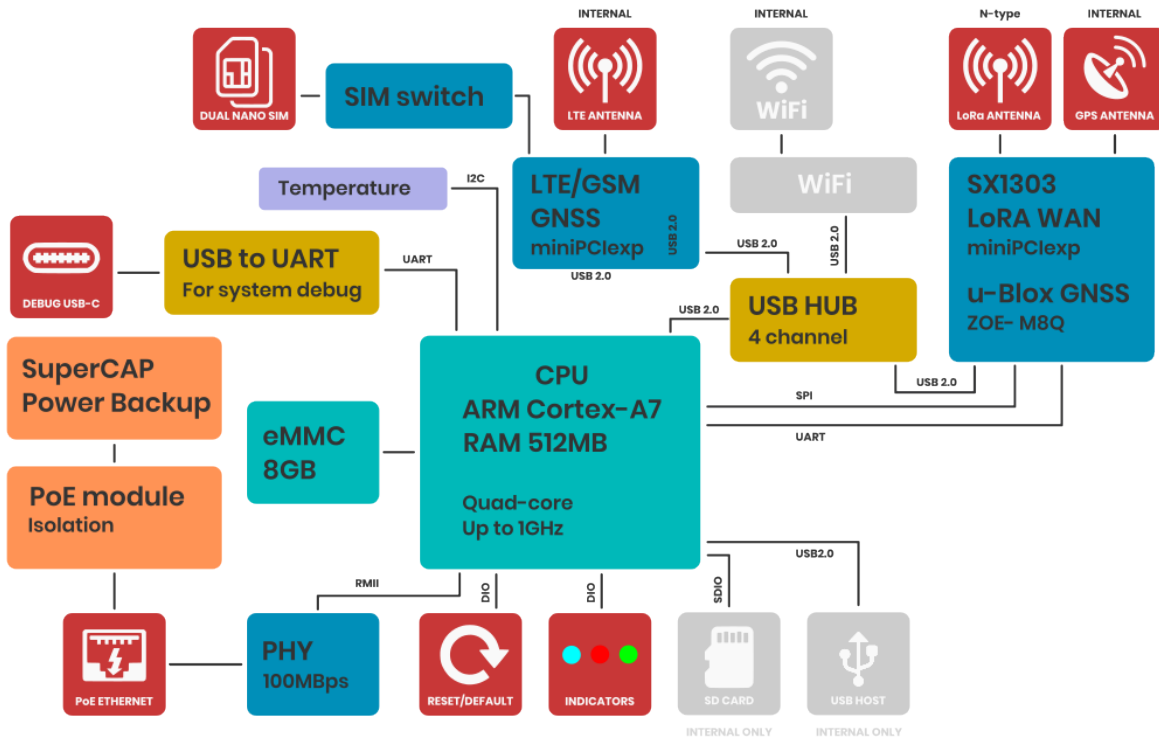

Note: USB host and microSD card are not available to the user. They are only for the purpose of developing your own software and updates. In case the user would like to use them, Atreyo's permission is required, otherwise the warranty will be void.

Configuration Manual

First start

After unpacking, the gateway is in ready-to-use condition but requires a few configurations to adapt to the required functions.

Power Supply

Connect the gateway to the power supply as referenced in the below diagram, and use the standard input/output-rated power adapter as per safety guidance.

The Gateway is to be powered via isolated **PoE** in the range of **37-57V DC**.

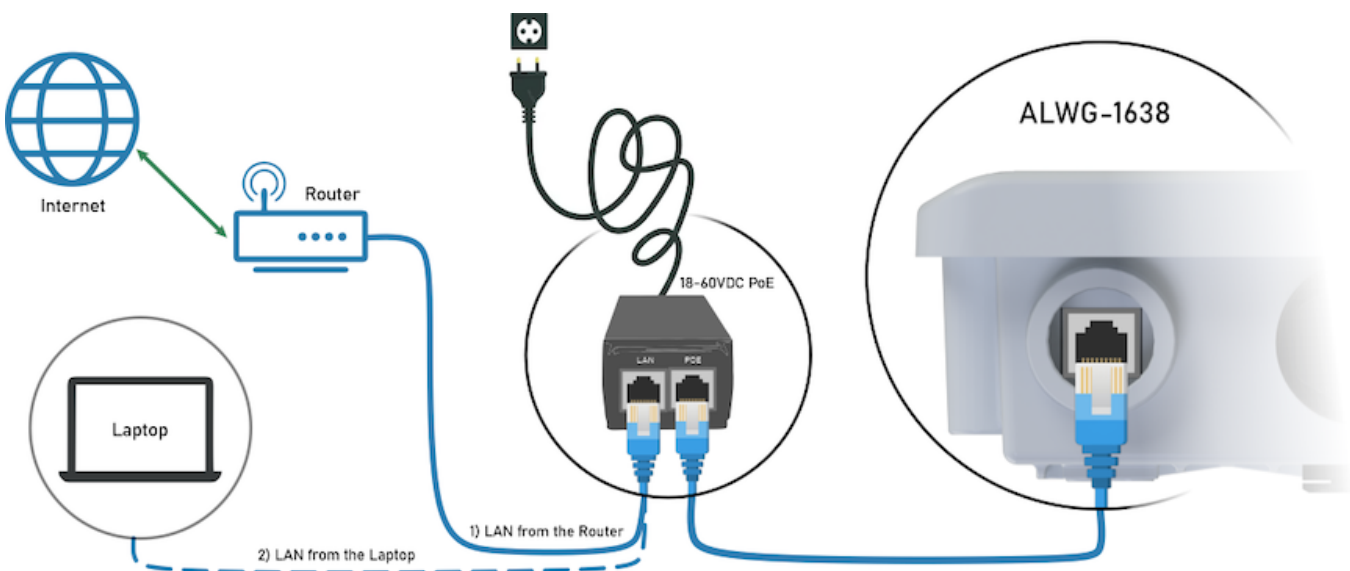

The above connection diagram shows two ways to connect the gateway to the network and power supply.

Connect to the network

DHCP

If the gateway is by default in DHCP mode proceed with method 1, which is to connect the gateway directly to your desired WAN network.

- Once connected as per the standard method you can find out the gateway IP of the gateway by using any IP scanner tool or using a command prompt by the "arp -a" command, to identify the gateway take reference to the Ethernet MAC ID.
- After getting the correct IP open any browser and enter the host IP there to access the web UI of the gateway.

Static IP

If the gateway is by default set to static IP, go for method 2 ... (Default)

- Connect the LAN cable to the laptop instead of the router and configure your Ethernet IPv4 settings as below, i.e 192.168.10.60
- After configuration open the browser and open the web UI using 192.168.10.60

IP assignment	Manual
IPv4 address:	192.168.10.100
IPv4 subnet prefix length	24
IPv4 gateway	192.168.10.60

Now, Go to **Network > interfaces** and switch IP protocol to "br-lan" to your desired settings.

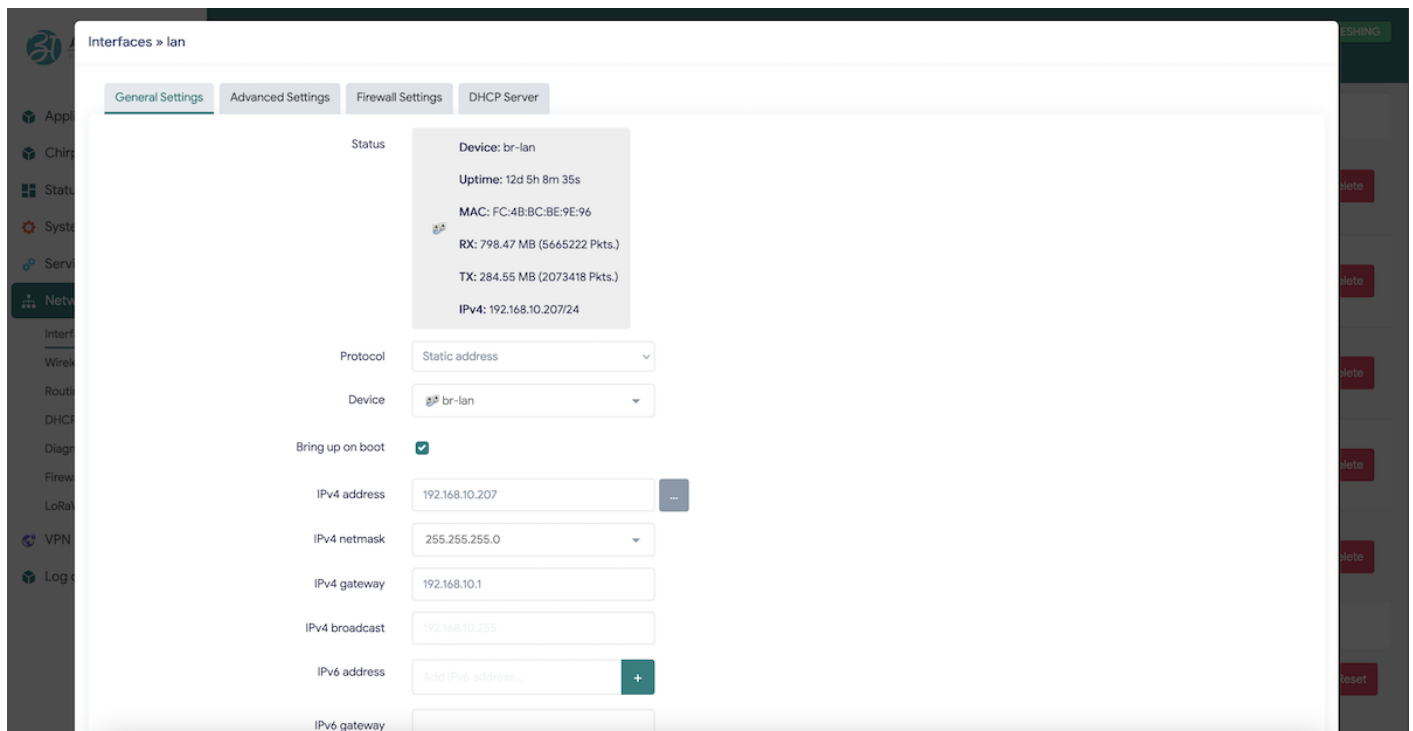

You can configure gateway either in DHCP client mode or else go for Static IP (as shown above), Feed your desired IP in static mode.

Once web UI access method is smoothly configured proceed to explore web UI configuration options after rebooting the gateway once.

Open the LuCI web interface

Through Ethernet

To access the LuCI WebUI, connect the gateway by your convenient method to the local network and enter the assigned IP address in any web browser. Please note that it may take some time from powering on the gateway to booting up the system. When the green LED in the bottom right side socket starts flashing, after about 10-15 seconds the built-in website becomes available to access.

Enter the host IP address and you will find the URL look a like as shown in the below image.

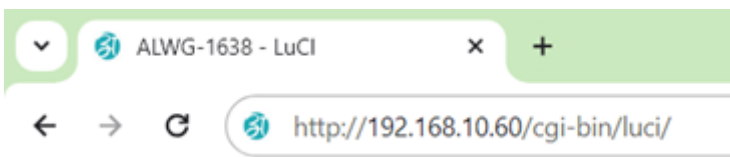

Below image shows the login page of Gateway webUI.

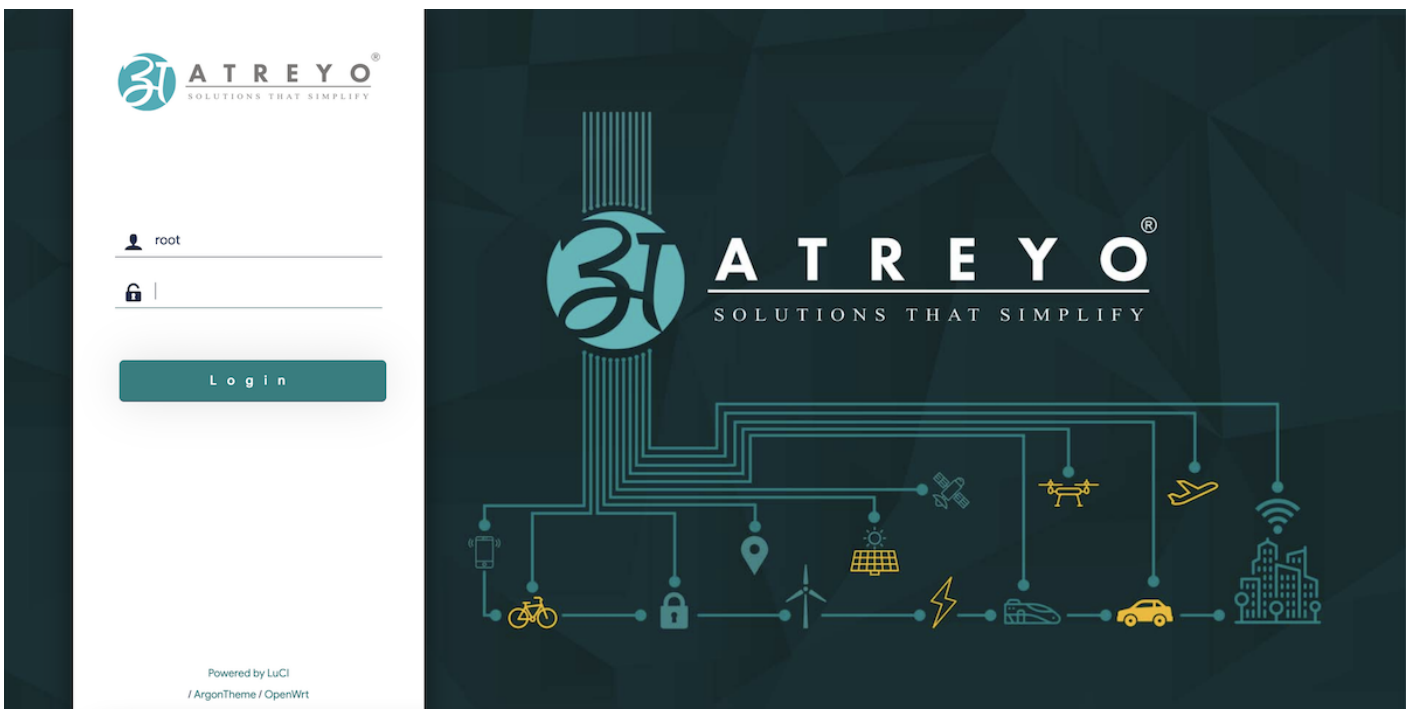

Default credentials are user/pass: **root/root**

Through the WiFi interface (if WiFi available)

By default, the gateway creates its hotspot, which is called "ALWG-1638". The network is unsecured. Connect to this network find out the host IP by the same method and enter the IP in the

address bar of your browser.

WiFi credentials : **ALWG-1638/atreyo12**

After logging in, you are automatically taken to the Application page:

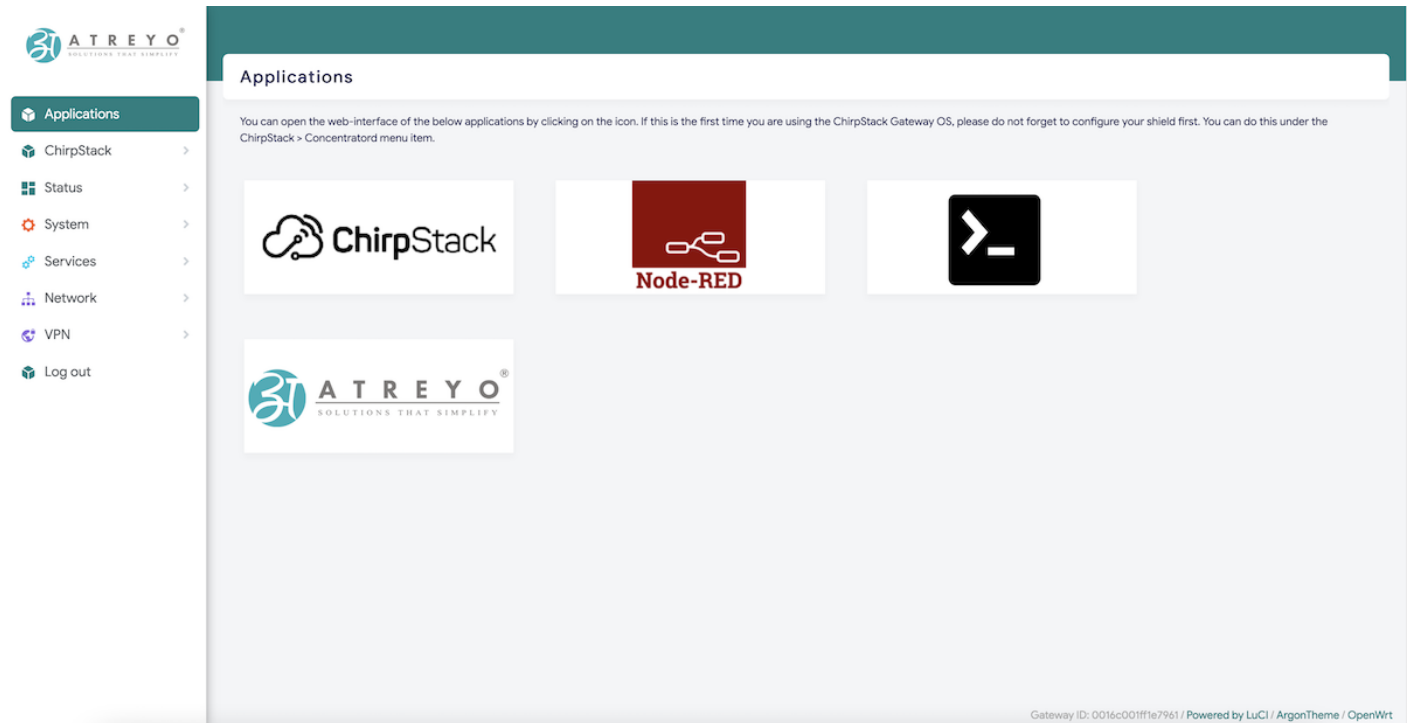

Chirpstack LNS and **NodeRED** and **Terminal** are pre-installed in the gateway.

If you are using the ChirpStack Gateway OS first time, do not forget to configure your shield first.

- Click the button in the Application to open it (it will open in a new tab)
- Terminal (CLI) is also hosted, that can be opened from the same menu

If you have a pop-up at the top with a message that no password has been set, set/change it.

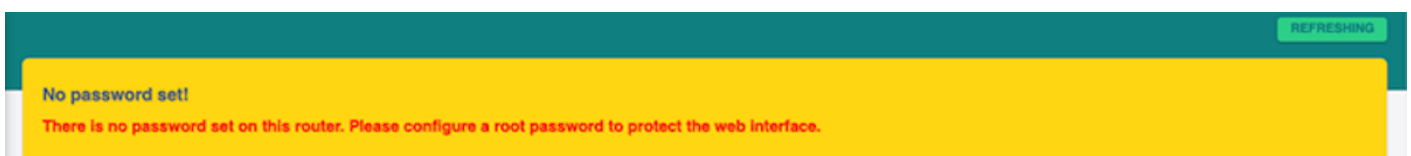

Set a password on the **System>Administration** page:

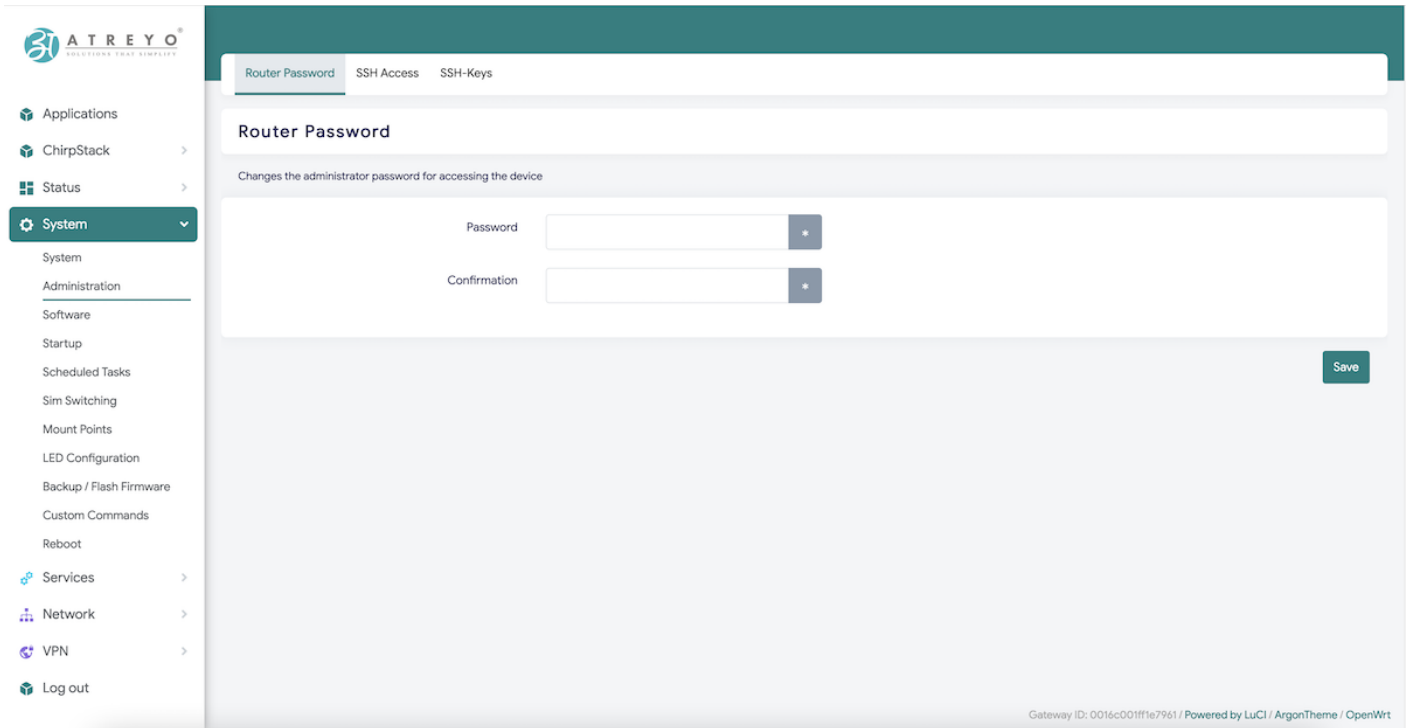

To maintain security, it is recommended to use long and complex passwords.

Chirpstack concentrator

ChirpStack Concentrator provides a unified API interface to LoRa(R) concentrator hardware. Please refer to the ChirpStack Concentrator Hardware page for supported hardware and configuration options.

This gateway has pre-installed chirpstack gateway OS and it has Chirpstack concentrator installed in it.

Basically it is used to configure respective shield (LoRa Chip) used in gateway.

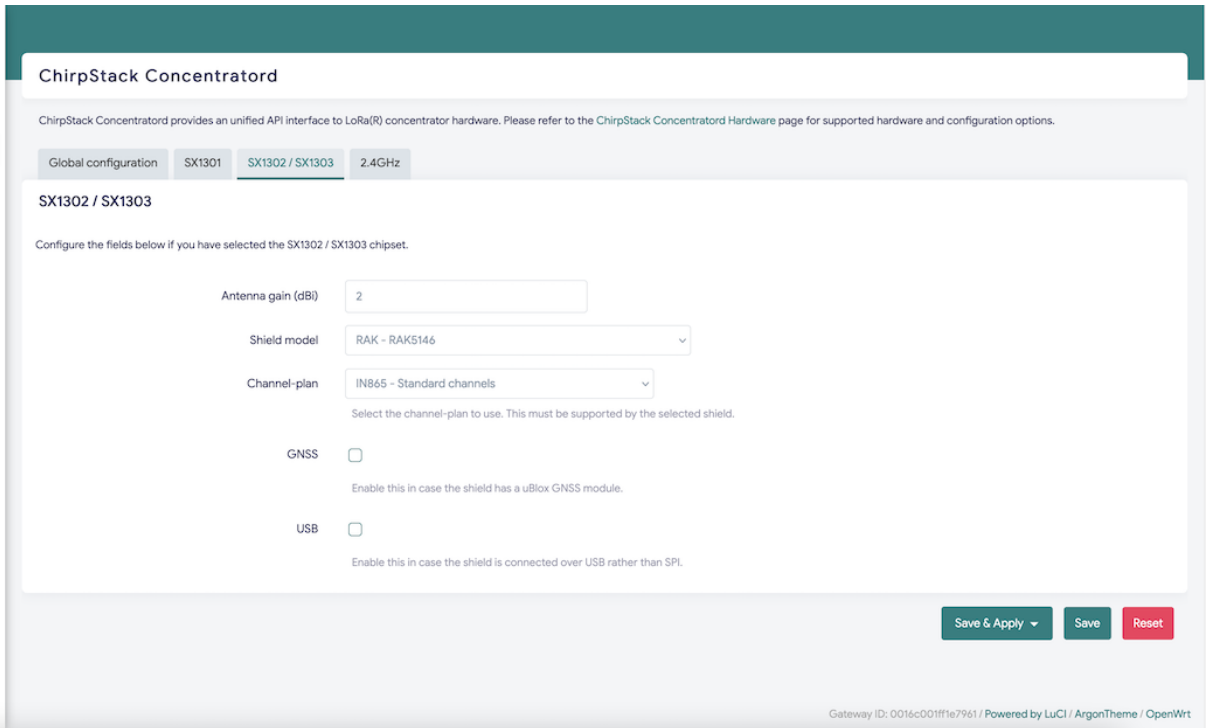

Antenna gain (dBi) , shield used in gateway, channel plan in which gateway should work ,etc, all these parameters can be configured in this section.

After shield setup gateway can be configured to in two different mode to send data 1) Chirpstack UDP forwarder and 2) Chirpstack MQTT forwarder.

Chirpstack forwarder

Gateway has inbuilt functionality pre-installed for ChirpStack Concentrator, in which one can setup shield and it's operating region.

The gateway is supported with

- Chirpstack UDP forwarder
- Chirpstack MQTT forwarder

Chirpstack UDP forwarder:

If your your LNS server is handling UDP Data then you need to configure LNS in UDP forwarder mode.

Follow below basic steps to send data to UDP forwarder.

Open **Chirpstack > UDP forwarder**



Add UDP server address along with port.

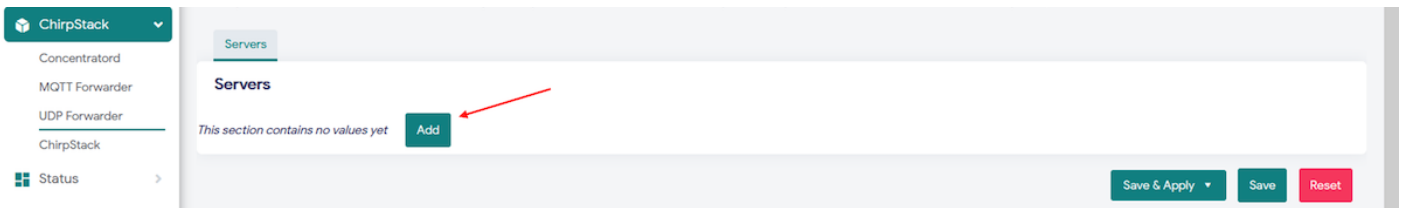

i.e.

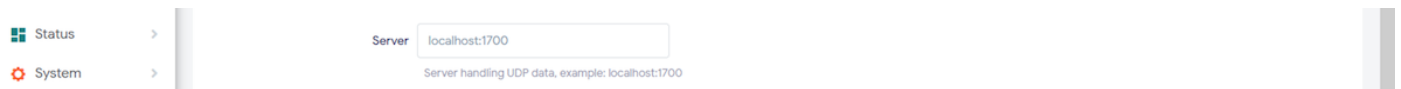

Save the configuration.

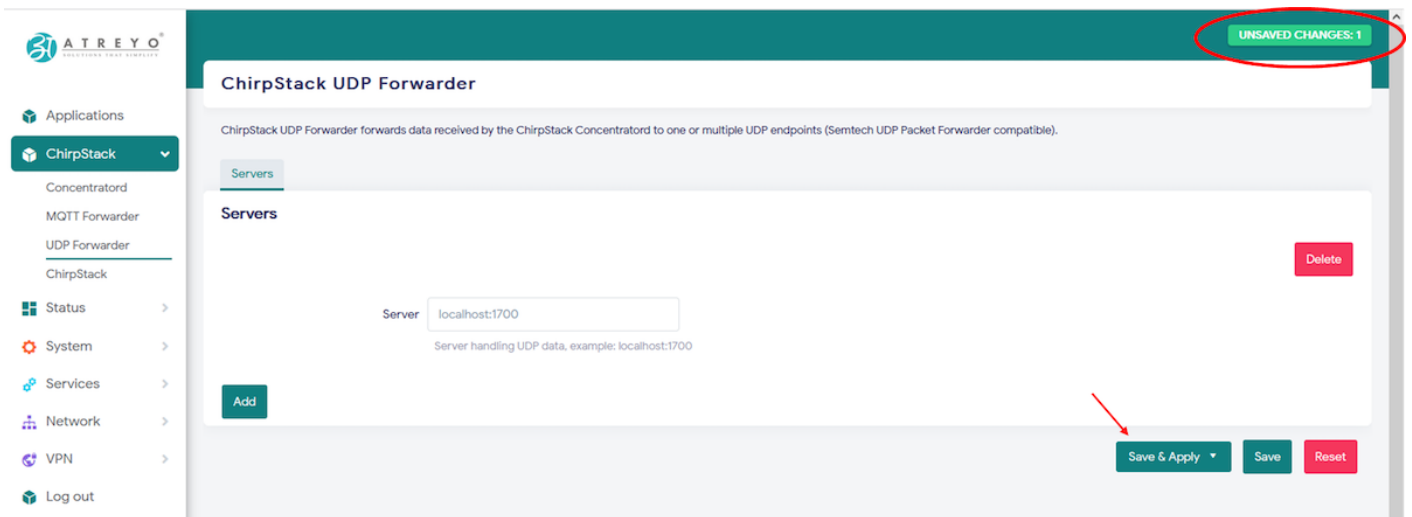

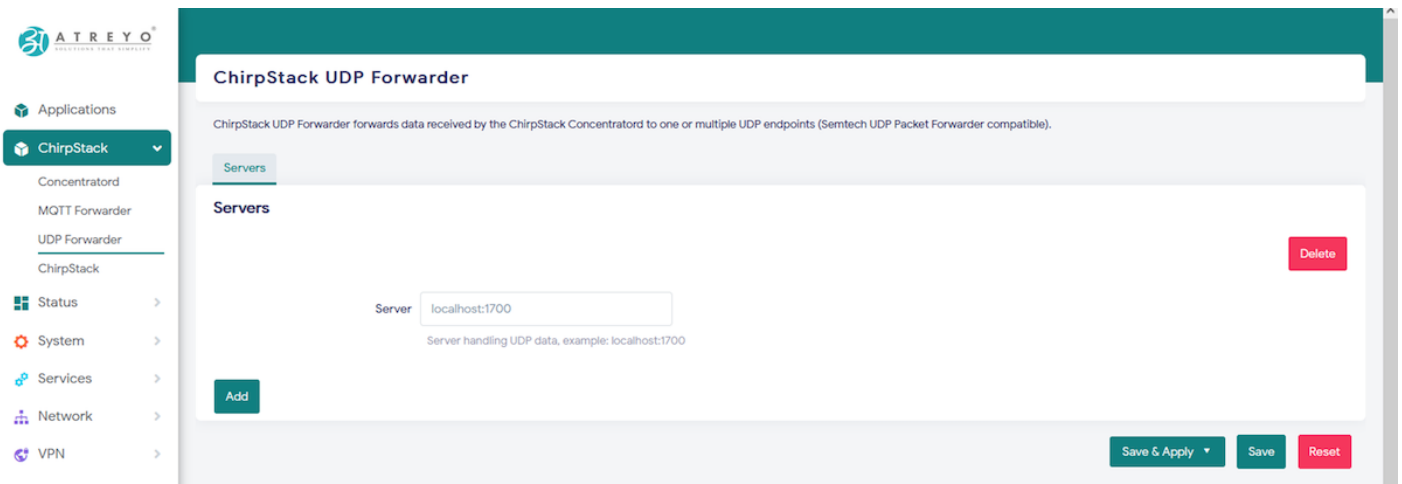

After adding LNS server you can see uplink forwarded to your UDP LNS server.

... in case need to delete UDP server, click the **Delete** button then **Save & Apply**

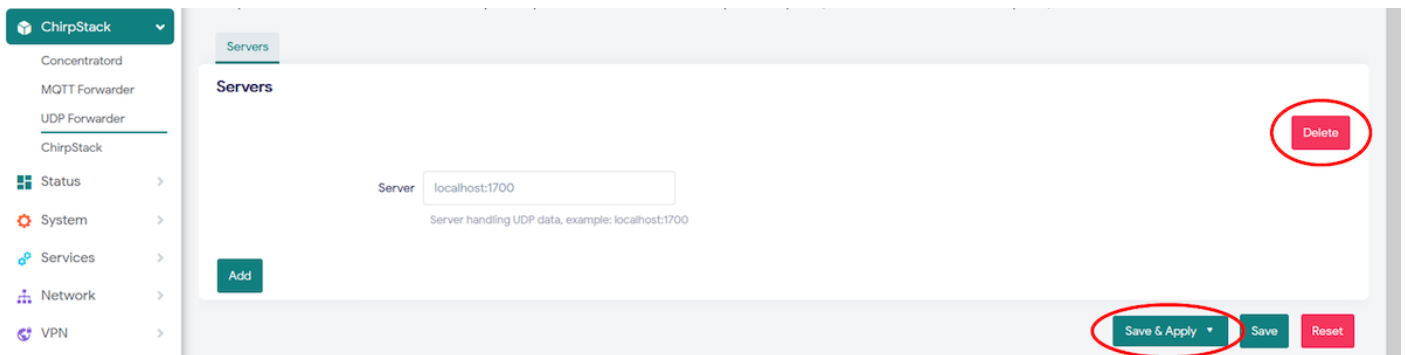

Chirpstack MQTT forwarder

If your your LNS server is handling Data over MQTT then you need to configure LNS in MQTT forwarder mode.

Follow below basic steps to send data to MQTT forwarder.

Open **Chirpstack** > **MQTT** forwarder

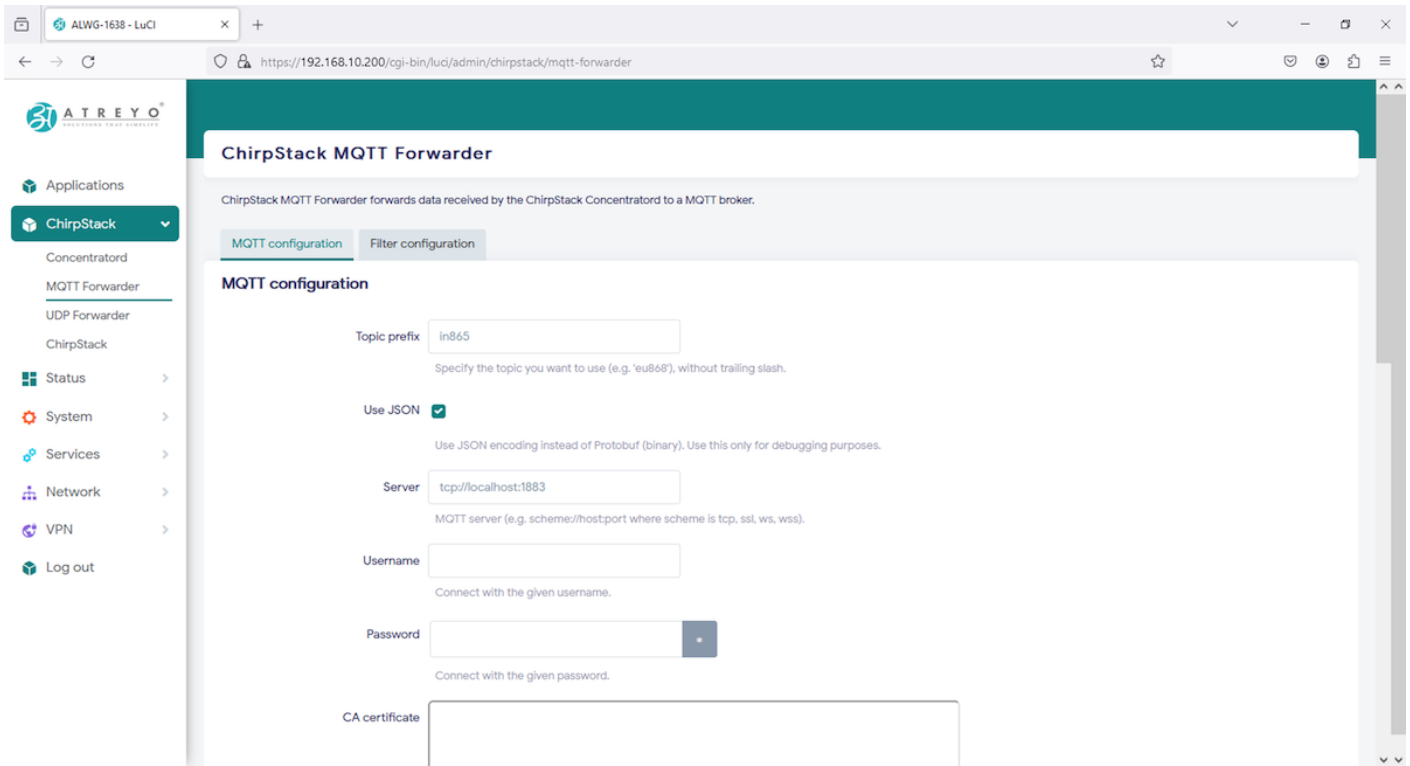

Add MQTT server address along with port.

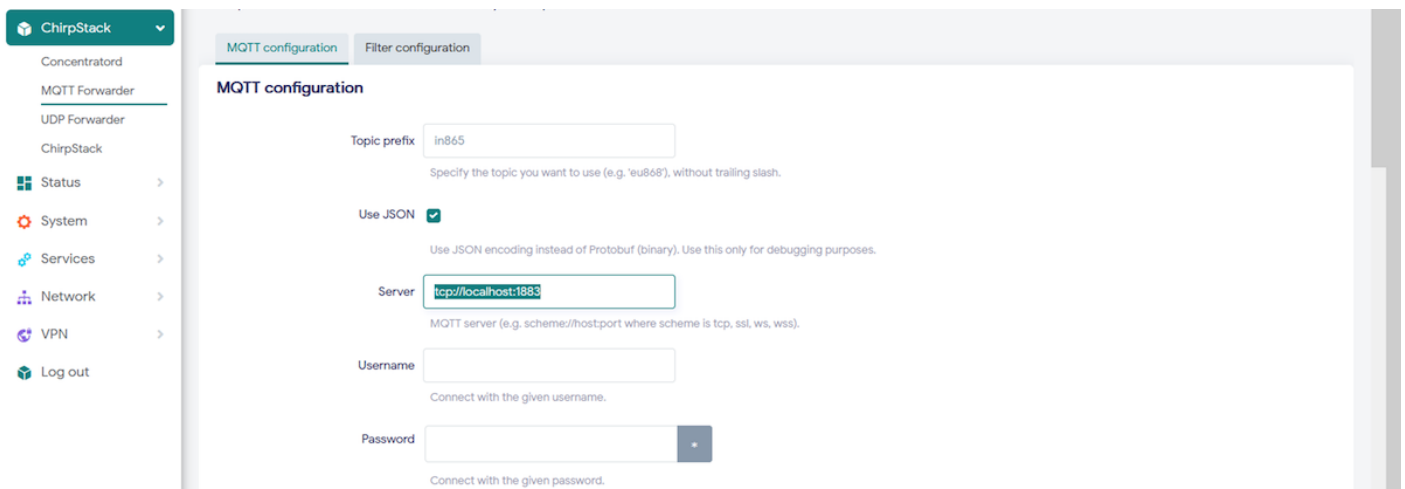

Topic prefix is by default from frequency , you can change it or keep as it is.

MQTT server is in this format --> e.g. scheme://host:port where scheme is tcp, ssl, ws, wss, so add your address accordingly (ignor address in picture)

You can provide user, password to connect if you MQTT server is defined in that way.

See how to configure gateway to send uplink/data to internal chirpstack LNS

Moreover you can add CA certificate, TLS certificate, and TLS key-file if needed.(copy paste the file contains, neither path to write or nor file you need to drag here).

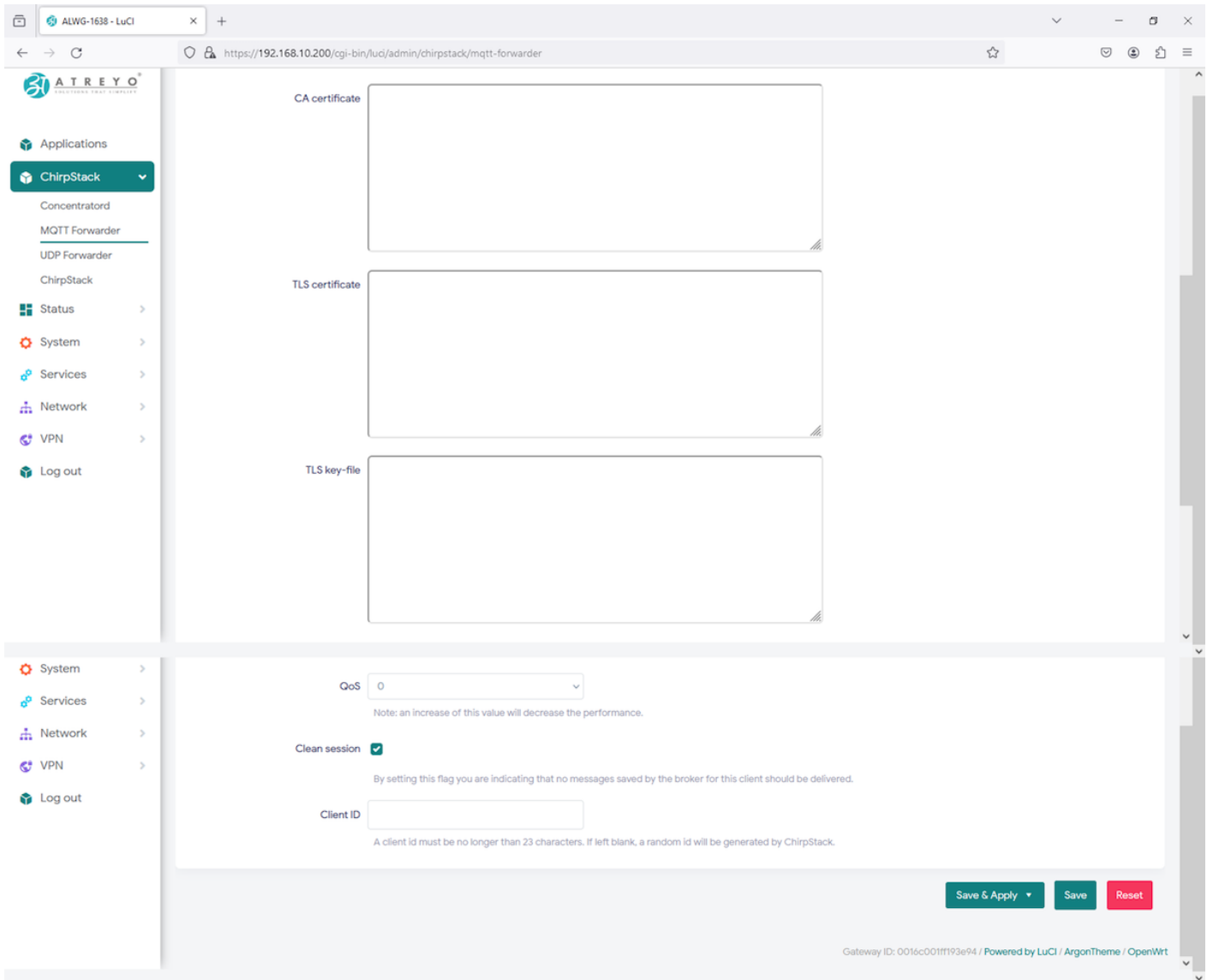

After adding configuration **Save & Apply**.

Uplink and Join-requests can be filtered based on the configured DevAddr prefixes and JoinEUI prefixes.

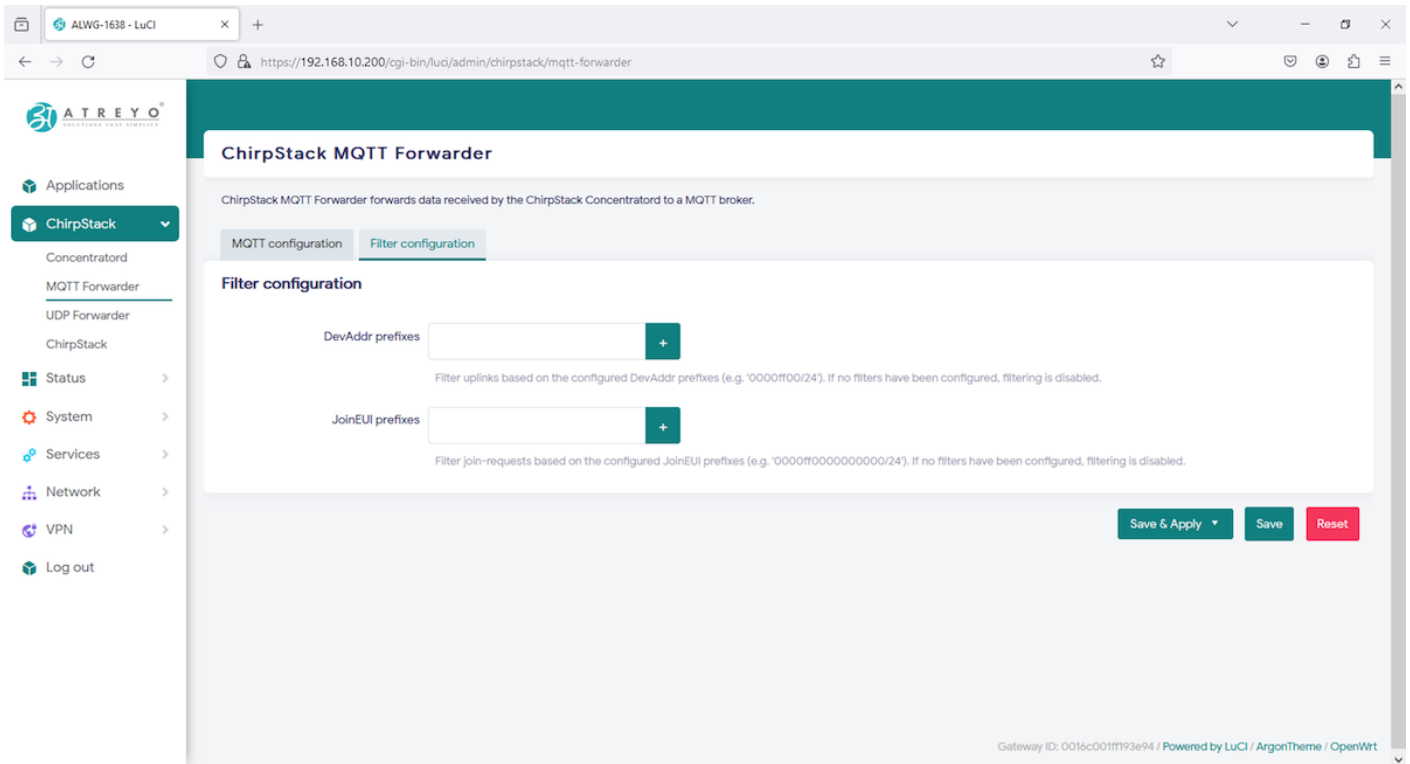

Once all configuration done, you can move to LNS server for further integration over cloud.

Chirpstack LNS

Refer **Chirpstack MQTT forwarder** in Chirpstack forwarder for basic idea to configure MQTT forwarder, When you open **Chirpstack > MQTT** forwarder add internal LNS server:port in Server and Save.

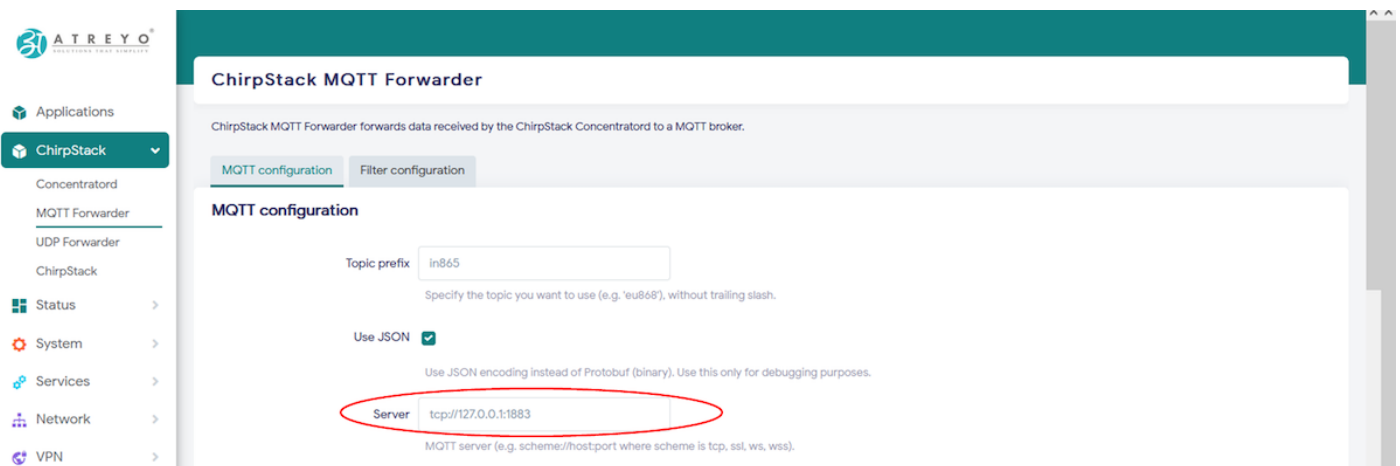

Read [chirpstack documentation](#) for MQTT forwarder, where MQTT **server="tcp://127.0.0.1:1883"** for connecting gateway to internal chirpstack LNS.

After adding server and saved it, gateway backend system will reset concentrator module to apply new configuration, System Log feature can have this information as shown below.

```
Mon Apr 1 18:14:39 2024 user.info chirpstack-concentrator-stx1302[5258]: Configuring reset pin, dev: /dev/gpio-chip0, pin: 17
Mon Apr 1 18:14:39 2024 user.info chirpstack-concentrator-stx1302[5258]: Starting Concentrator SX1302 (version: 4.3.1, docs: https://www.chirpstack.io/docs/chirpstack-concentrator/)
Mon Apr 1 18:14:39 2024 user.info chirpstack-concentrator-stx1302[5258]: 4.3.1 Atreyo mode - triggering stx1302 reset on P1_07
Mon Apr 1 18:14:39 2024 user.info chirpstack-concentrator-stx1302[5258]: Setting I2C device path, path: /dev/i2c-1
Mon Apr 1 18:14:39 2024 user.info chirpstack-concentrator-stx1302[5258]: Setting board configuration, lorawan_public: true, clock_source: 0, com_type: Spi, com_path: /dev/spidev0.0
Mon Apr 1 18:14:39 2024 user.info chirpstack-concentrator-stx1302[5258]: Setting up fine timestamp, enable: false
Mon Apr 1 18:14:39 2024 user.info chirpstack-concentrator-stx1302[5258]: Setting up concentrator channels
Mon Apr 1 18:14:39 2024 user.info chirpstack-concentrator-stx1302[5258]: Configuring radio, radio: 0, enabled: true, center_freq: 865462500, type: SX1250
Mon Apr 1 18:14:39 2024 user.info chirpstack-concentrator-stx1302[5258]: Configuring radio, radio: 1, enabled: true, center_freq: 866385000, type: SX1250
Mon Apr 1 18:14:39 2024 user.info chirpstack-concentrator-stx1302[5258]: Setting up concentrator channels
Mon Apr 1 18:14:39 2024 user.info chirpstack-concentrator-stx1302[5258]: Configuring multi-SF LoRa channel, channel: 0, enabled: true, freq: 865062500, rf_chain: 0, if_freq: -400000
Mon Apr 1 18:14:39 2024 user.info chirpstack-concentrator-stx1302[5258]: Configuring multi-SF LoRa channel, channel: 1, enabled: true, freq: 865402500, rf_chain: 0, if_freq: -400000
Mon Apr 1 18:14:39 2024 user.info chirpstack-concentrator-stx1302[5258]: Configuring multi-SF LoRa channel, channel: 2, enabled: true, freq: 865985000, rf_chain: 1, if_freq: -400000
Mon Apr 1 18:14:39 2024 user.info chirpstack-concentrator-stx1302[5258]: Configuring multi-SF LoRa channel, channel: 3, enabled: false, freq: 0, rf_chain: 0, if_freq: 0
Mon Apr 1 18:14:39 2024 user.info chirpstack-concentrator-stx1302[5258]: Configuring multi-SF LoRa channel, channel: 4, enabled: false, freq: 0, rf_chain: 0, if_freq: 0
Mon Apr 1 18:14:39 2024 user.info chirpstack-concentrator-stx1302[5258]: Configuring multi-SF LoRa channel, channel: 5, enabled: false, freq: 0, rf_chain: 0, if_freq: 0
Mon Apr 1 18:14:39 2024 user.info chirpstack-concentrator-stx1302[5258]: Configuring multi-SF LoRa channel, channel: 6, enabled: false, freq: 0, rf_chain: 0, if_freq: 0
Mon Apr 1 18:14:39 2024 user.info chirpstack-concentrator-stx1302[5258]: Configuring multi-SF LoRa channel, channel: 7, enabled: false, freq: 0, rf_chain: 0, if_freq: 0
Mon Apr 1 18:14:39 2024 user.info chirpstack-concentrator-stx1302[5258]: Configuring Std LoRa channel, enabled: false, freq: 0, rf_chain: 0, if_freq: 0
Mon Apr 1 18:14:39 2024 user.info chirpstack-concentrator-stx1302[5258]: Configuring FSK channel, enabled: false, freq: 0, rf_chain: 0, if_freq: 0
Mon Apr 1 18:14:39 2024 user.info chirpstack-concentrator-stx1302[5258]: Starting the concentrator
Mon Apr 1 18:14:39 2024 user.info chirpstack-mqtt-forwarder[5317]: Starting ChirpStack MQTT Forwarder (version: 4.1.3, docs: https://www.chirpstack.io)
Mon Apr 1 18:14:39 2024 user.info chirpstack-mqtt-forwarder[5317]: Setting up ChirpStack Concentrator backend
Mon Apr 1 18:14:39 2024 user.info chirpstack-mqtt-forwarder[5317]: Setting up ChirpStack Concentrator backend
Mon Apr 1 18:14:39 2024 user.info chirpstack-mqtt-forwarder[5317]: Connecting to Concentrator event API, event_url: ipc:///tmp/concentrator_event
Mon Apr 1 18:14:39 2024 user.info chirpstack-mqtt-forwarder[5317]: Connecting to Concentrator command API, command_url: ipc:///tmp/concentrator_command
Mon Apr 1 18:14:39 2024 user.info chirpstack-mqtt-forwarder[5317]: Reading gateway id
```

Once it has been reset/restarted successfully, it will start functioning normally.

Gateway configuration is all set to move ahead into LNS configuration.

As like NodeRED, Chirpstack LNS is pre-installed in system as well as can be opened from same Application menu by clicking the icon or "**<gateway_IP>:8080**".

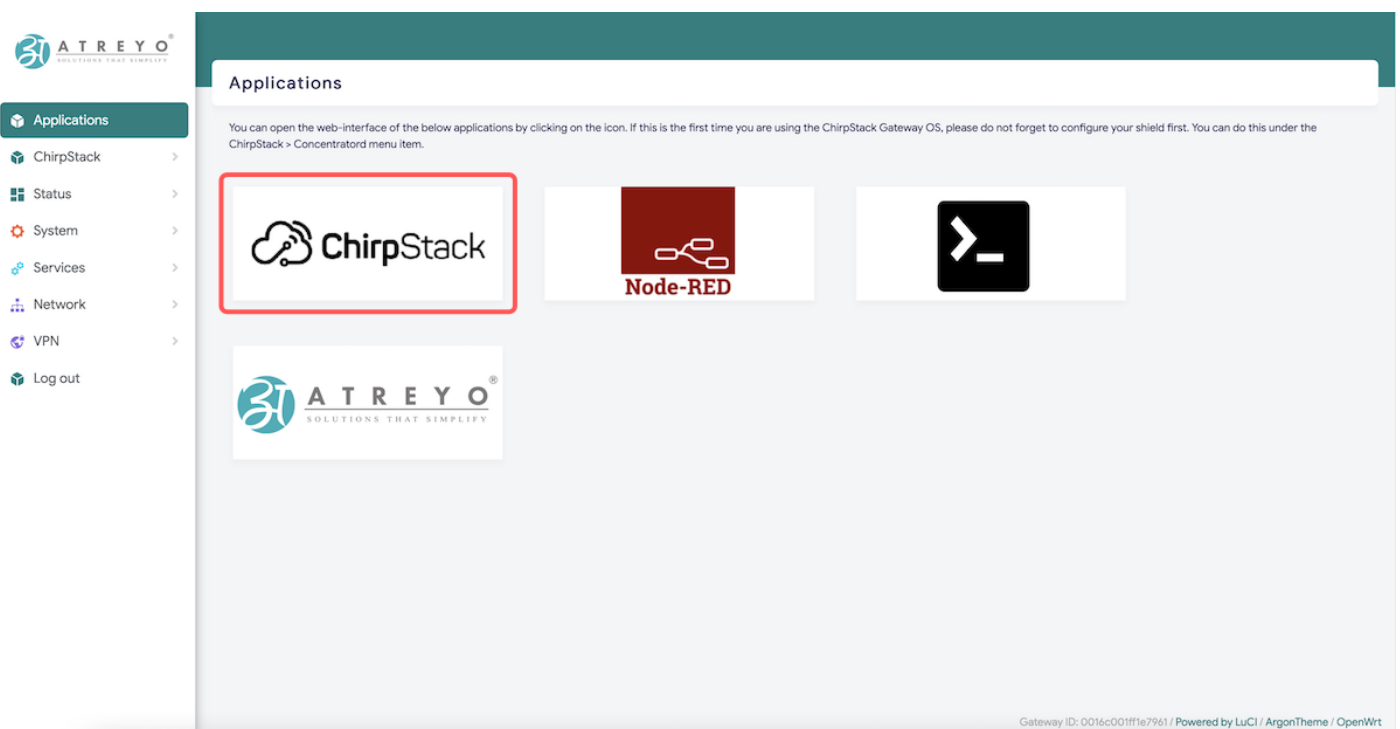

Chirpstack will ask credential to login into chirpstack console.

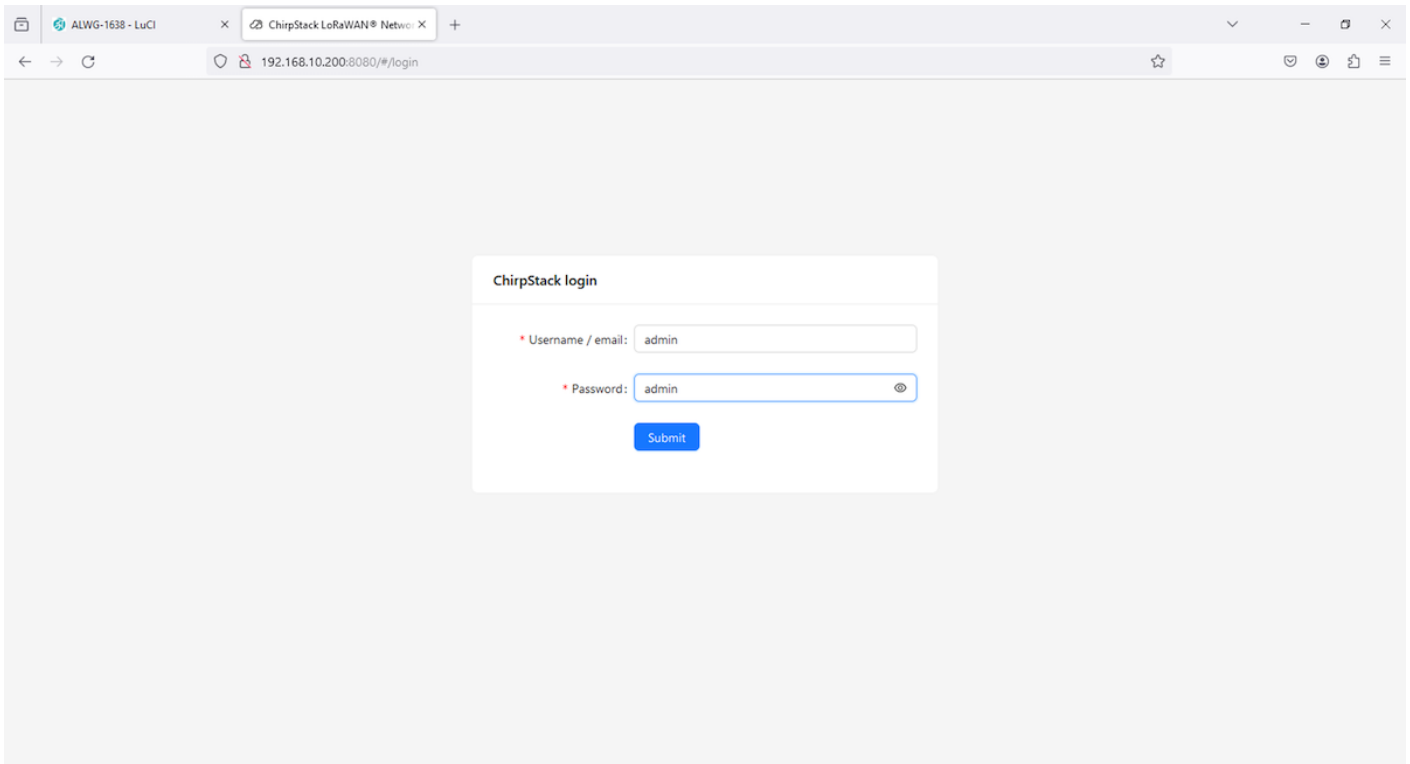

Credentials : user/pass --> admin/admin , Make sure to change it later for security purpose.

After login you will be redirected to Dashboard, where you can see gateway and end devices online/offline status, device dat-rate usage as well as Gateway Map.

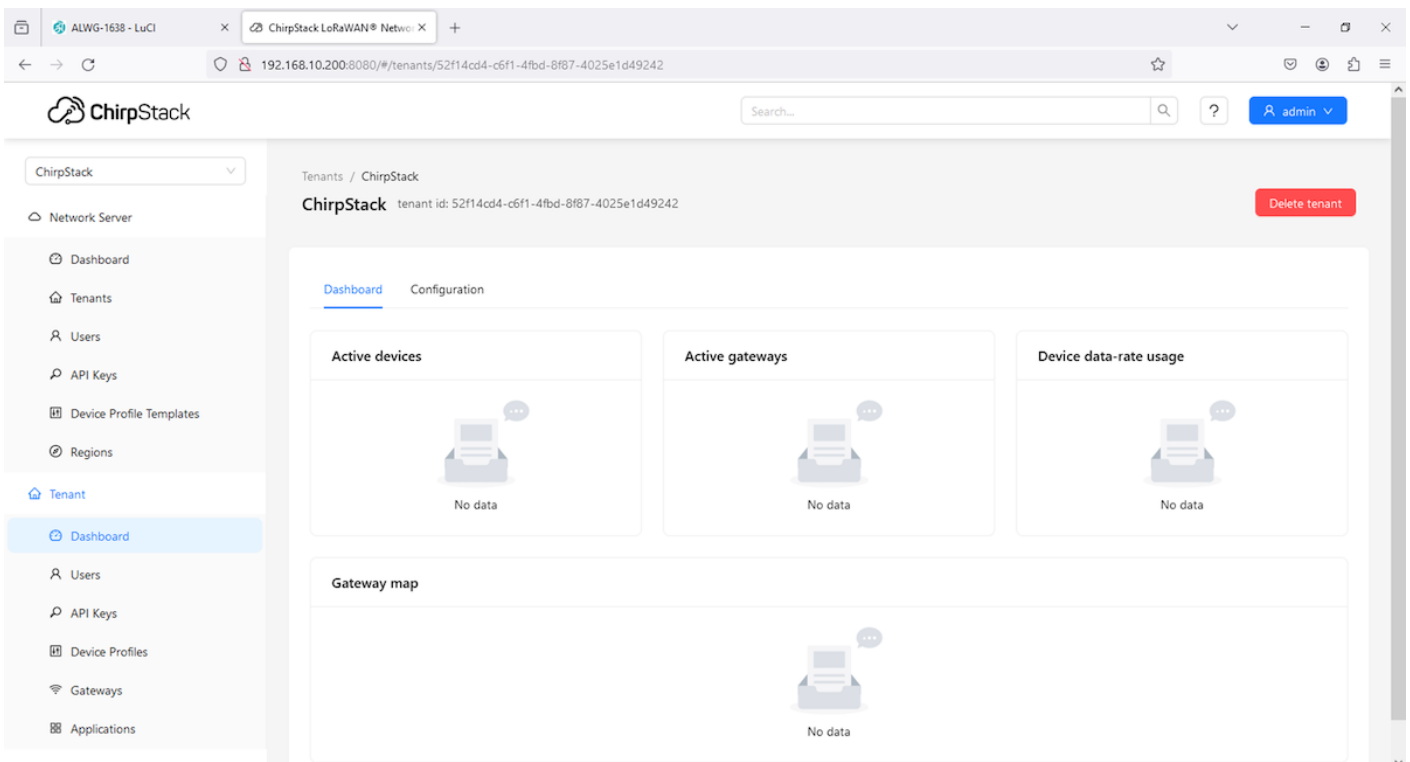

in above data there in No Data, as no Gateways/Devices has been added.

Cellular modem

Modem

The Gateway in its basic configuration is equipped with an LTE modem that also supports GPRS and SMS functions. Different modems were used depending on the model variant. Here is a table of models.

SIM card

The Gateway supports two microSIM cards, both 1.8V and 3V. The card connector is a push-pull type. When installing the SIM card, pay attention to the correct insertion of the card, and it's direction.

Refer to the below image for the SIM insertion guide.

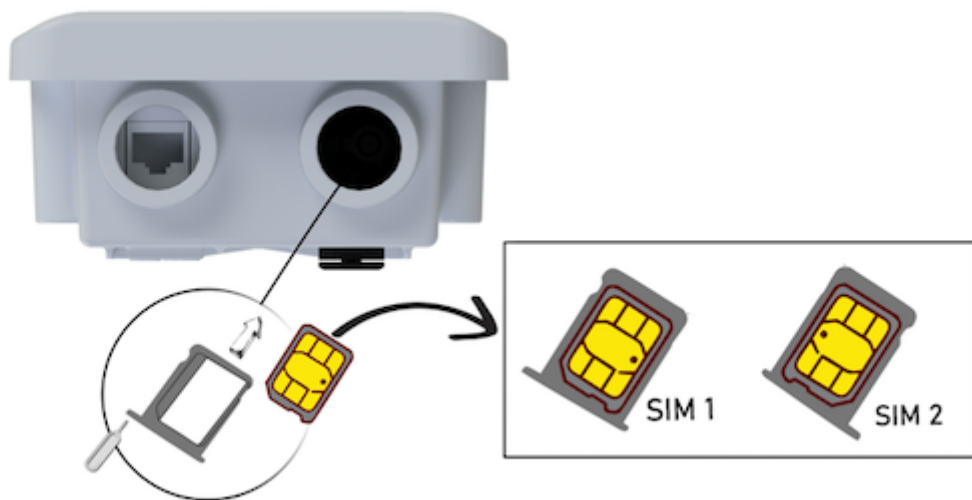

Activate Cellular Network

To activate the LTE modem, go to **Network > Interfaces** and select the **3g-wan** tab there.

REFRESHING

Interfases | Devices | Global network options

Interfases

lan	Protocol: Static address Uptime: 12d 7h 8m 41s MAC: FC:4B:BC:BE:9E:96 RX: 808.92 MB (5764643 Pkts.) TX: 303.38 MB (2105054 Pkts.) IPv4: 192.168.10.207/24	Restart Stop Edit Delete
lan6	Protocol: DHCPv6 client Uptime: 12d 7h 8m 34s MAC: FC:4B:BC:BE:9E:96 RX: 808.92 MB (5764643 Pkts.) TX: 303.38 MB (2105054 Pkts.)	Restart Stop Edit Delete
wan	Protocol: UMTS/GPRS/EV-DO RX: 0 B (0 Pkts.) TX: 0 B (0 Pkts.) Error: Network device is not present	Restart Stop Edit Delete
wwan	Protocol: DHCP client Information: Not started on boot	Restart Stop Edit Delete
wwan2	Protocol: DHCP client Error: Network device is not present	Restart Stop Edit Delete

Add new interface...

Save & Apply | Save | Reset

The interface is pre-configured but you might need to provide/change the network operator's APN, sometimes it also requires a username and password. Enter the required data and save.

Click the Edit button and enter APN.

Interfases » wan

General Settings | Advanced Settings | Firewall Settings | DHCP Server

Status	Device: 3g-wan RX: 0 B (0 Pkts.) TX: 0 B (0 Pkts.) Error: Network device is not present
Protocol	UMTS/GPRS/EV-DO
Bring up on boot	<input checked="" type="checkbox"/>
Modem device	/dev/ttyUSB0
Service Type	LTE
APN	INTERNET
PIN	
PAP/CHAP username	
PAP/CHAP password	
Dial number	****

Dismiss | Save

Then go to **System > Custom Commands**.

Here you will find below highlighted 4 scripts that are related to cellular modems.

- Modem ON - To give power to the cellular modem to use it.
- Modem OFF - To power down the cellular modem.
- SIM 1 - By default SIM 1 will be operated, still by this script SIM 1 can be operated.
- SIM 2 - To switch to SIM 2.

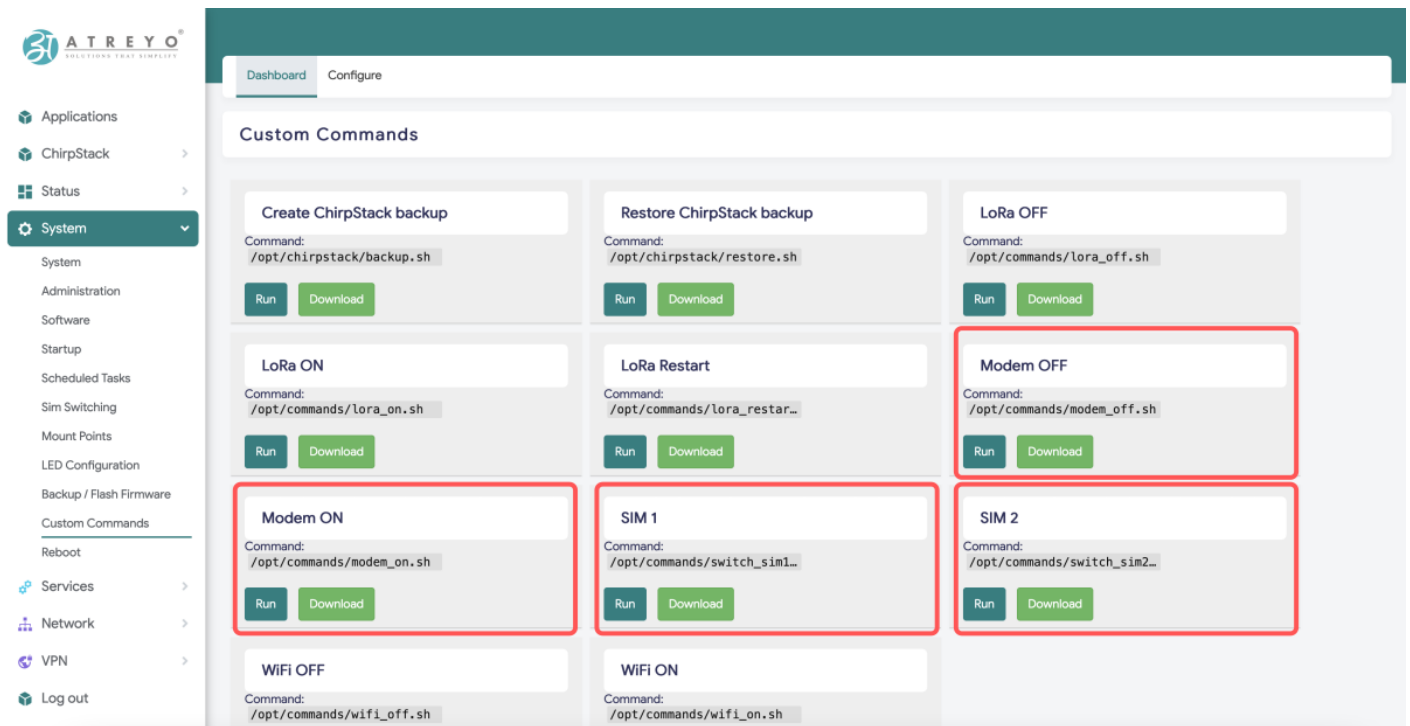

Once the script is successful you will get a pop-up at top right corner (Ref image below).

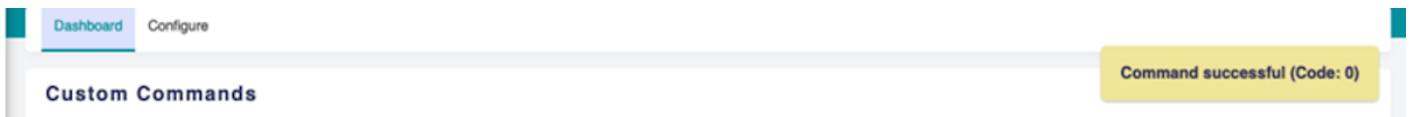

The modem will start up and connect to the Internet. To check if it is working properly and what the signal is, go to **Status > Mobile Service**.

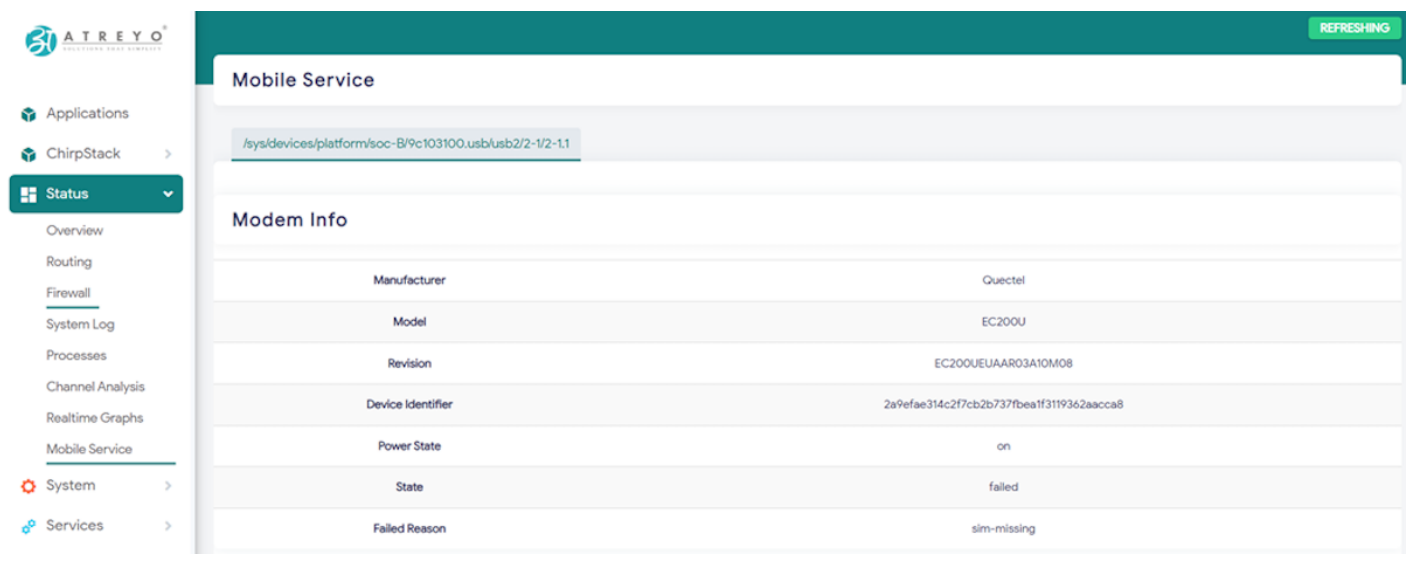

Cellular modem power ON at boot

To make the gateway automatically connect to the GSM Internet after startup, you need to add a modem startup in the System > Startup section under Local Startup, and add script path before 'exit 0'.

```
/usr/commands/modem_on.sh
```

Then save the changes.

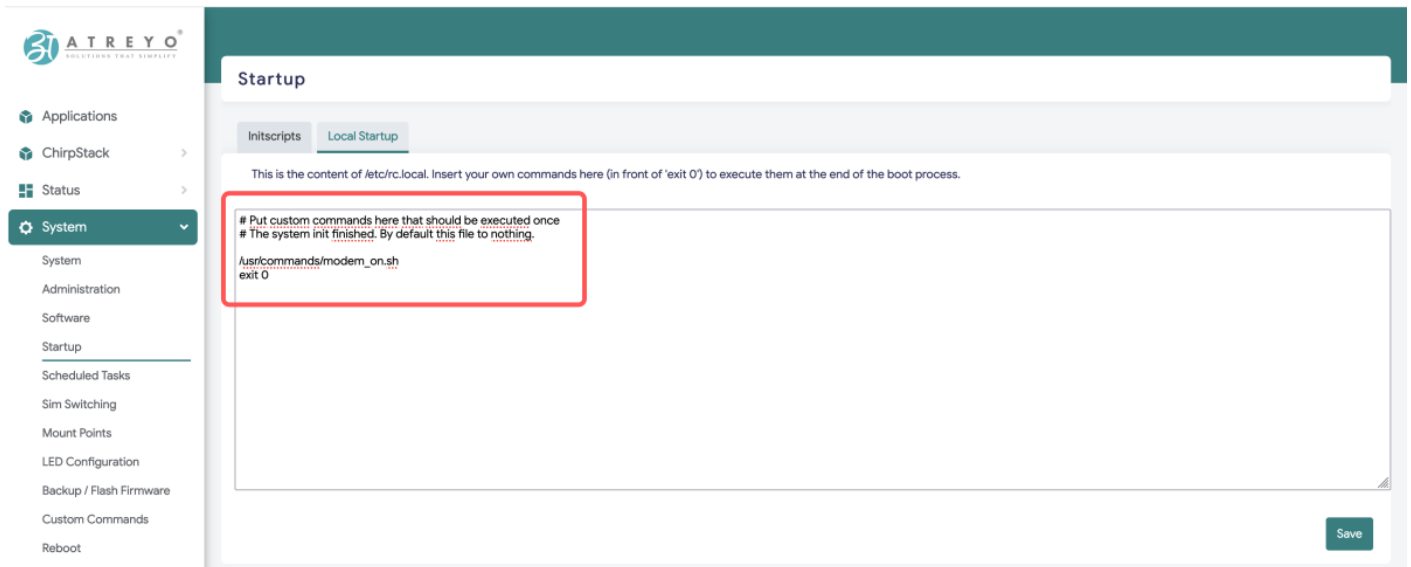

After each reboot, the gateway will automatically start the modem and connect to the GSM network.

Terminal

Few Gateway configuration need to be done using CLI or some backend files need to be edited or for any CLI based operation we need terminal, Hence same as NodeRED you can click on Terminal icon and it will open terminal in new tab or you can directly open in browser by "

```
<gateway_IP>:7681"
```

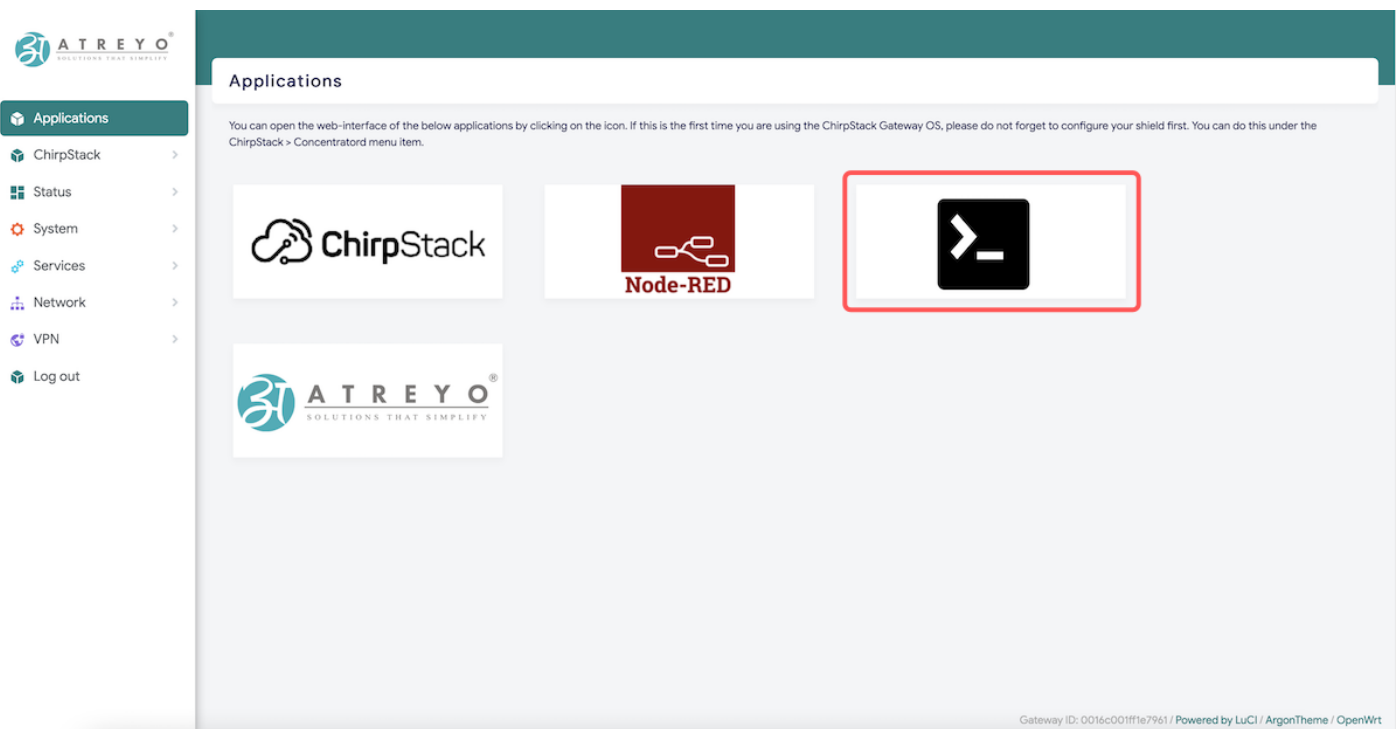

After clicking icon terminal will open in new tab and ask for user/password , it's same as gateway login.

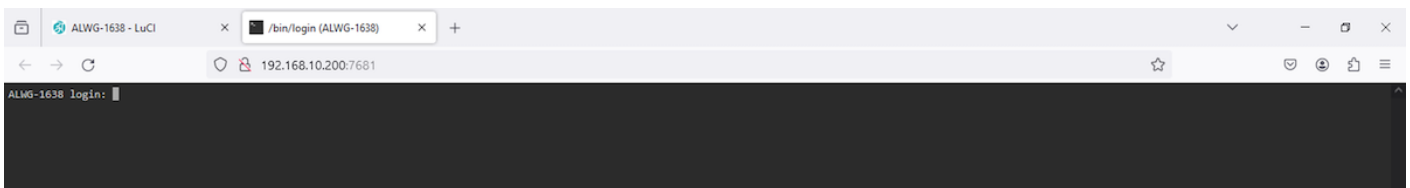

Credentials --> user/pass : **root/root**

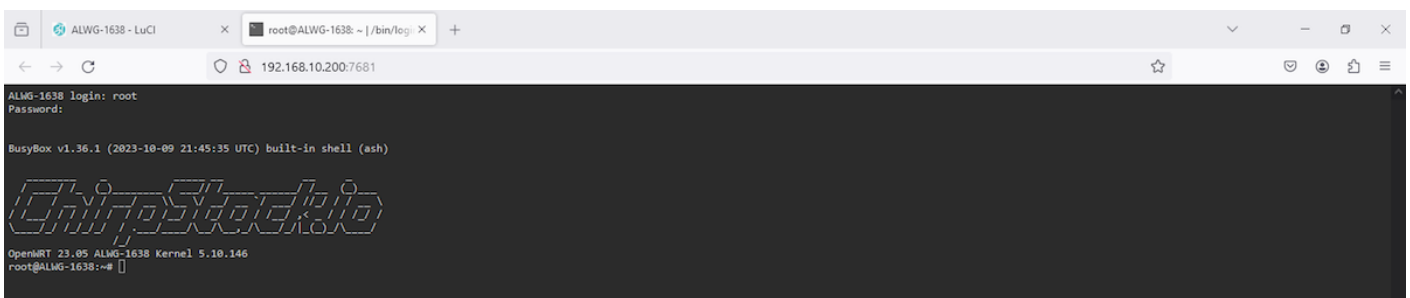

Now CLI utility can be used for any specific purpose.

Chirpstack LNS

Once the Chirpstack LNS has been configured in gateway side, few things to be done in Chirpstack console. i.e. to add Gateway, End devices, Application etc.

to **Add gateway** in chirpstack LNS open chirpstack LNS by clicking the icon in Application.

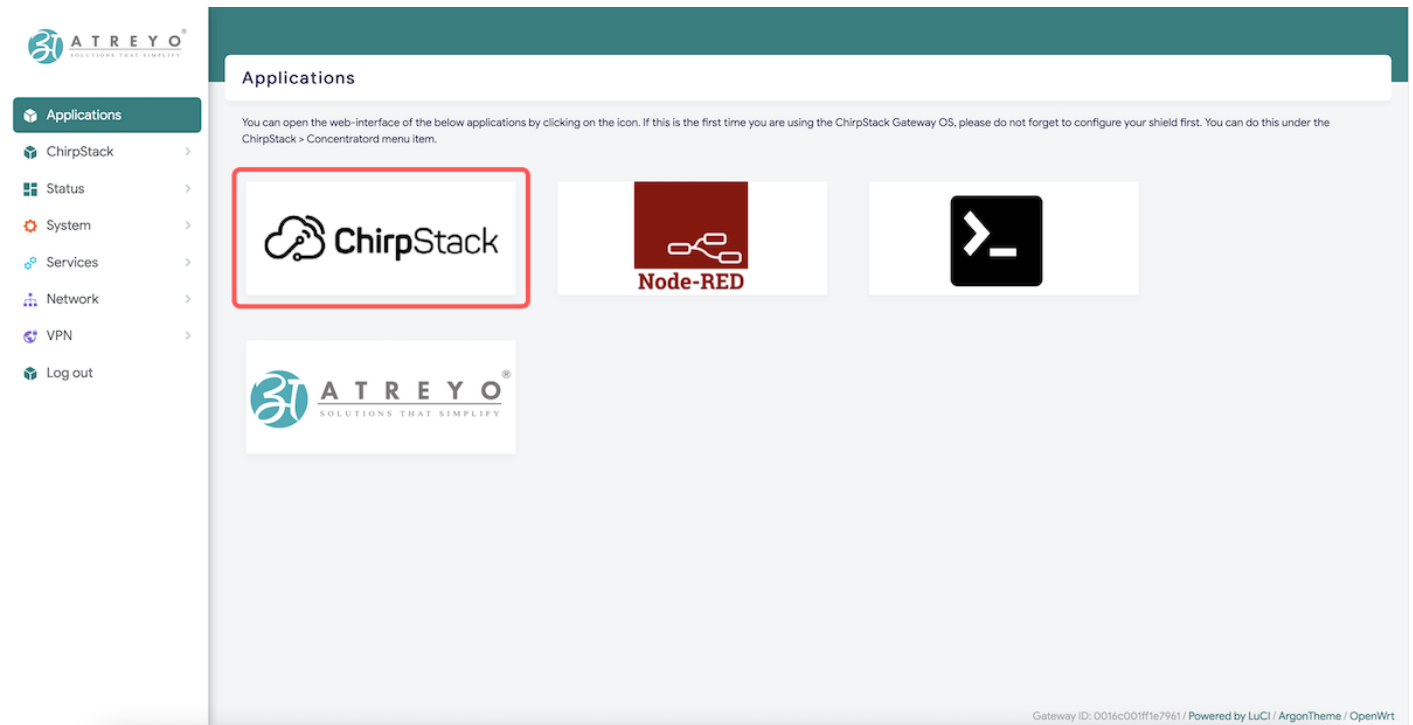

Login pop-up will appear, use admin/admin as user/pass. After login the screen will be like:

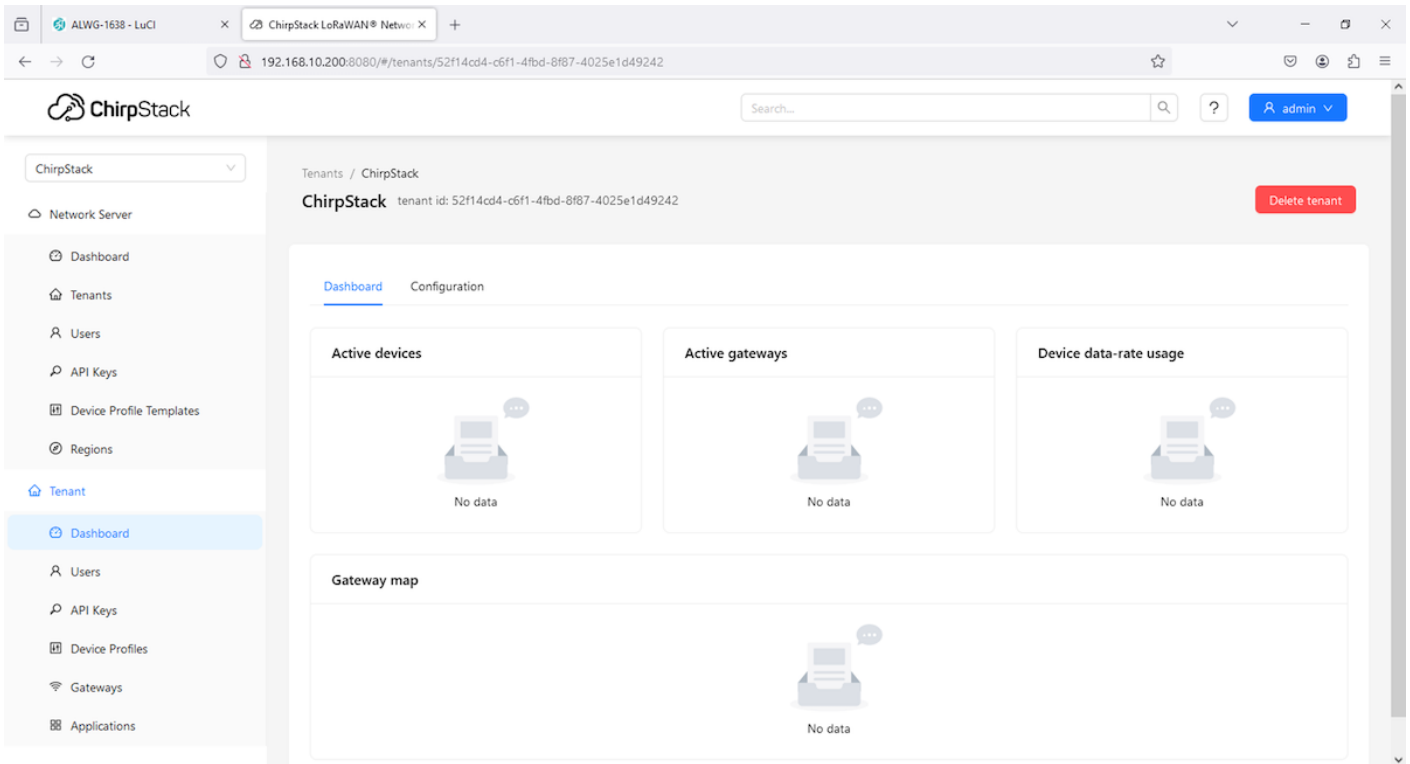

Go to Gateway section in Tenant to add particular gateway.

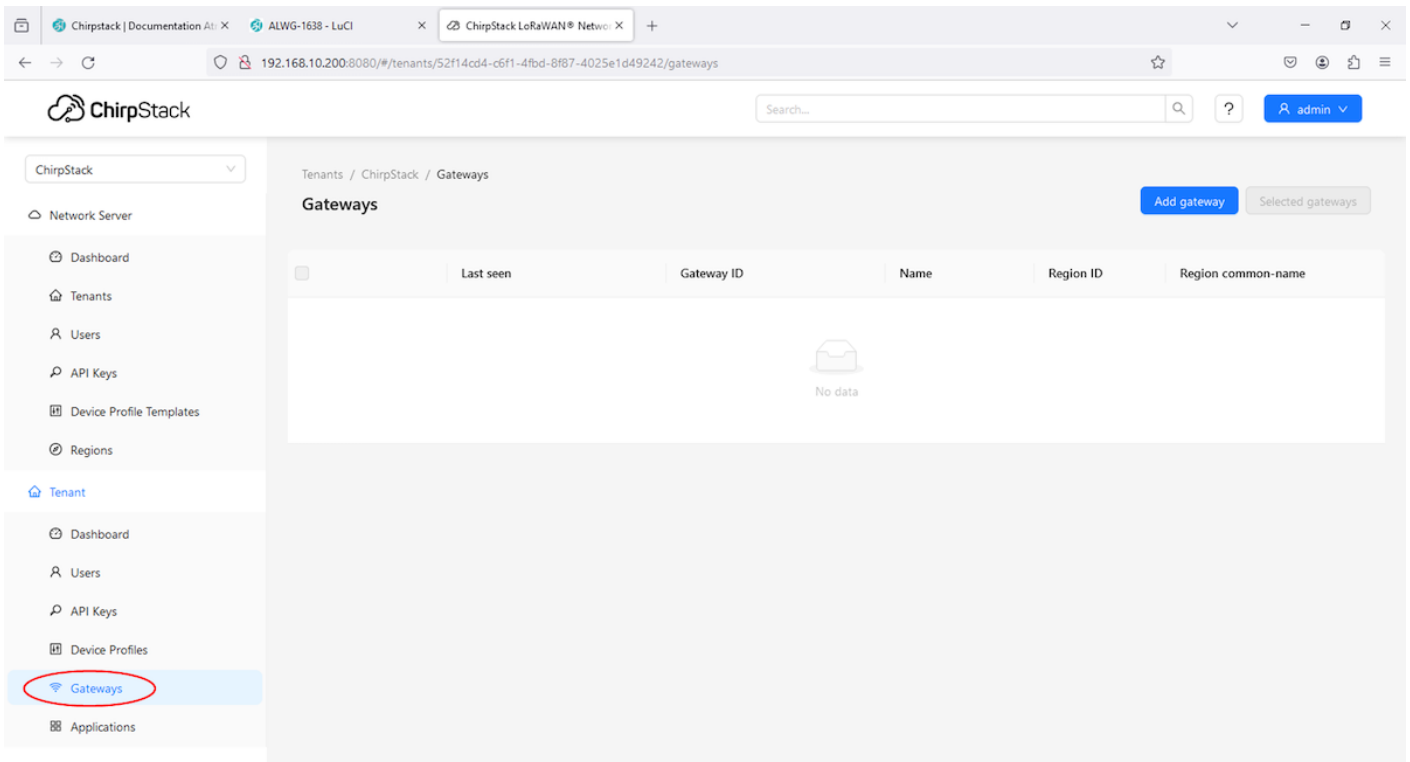

Click on **Add gateway** button.

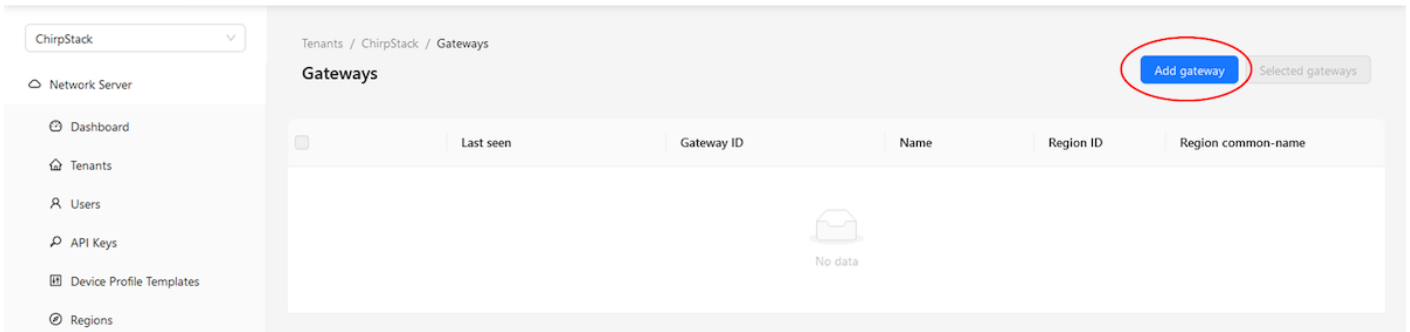

It will open another page and ask for Gateway Name, it's EUI and any description you want to add for sack of your application purpose.

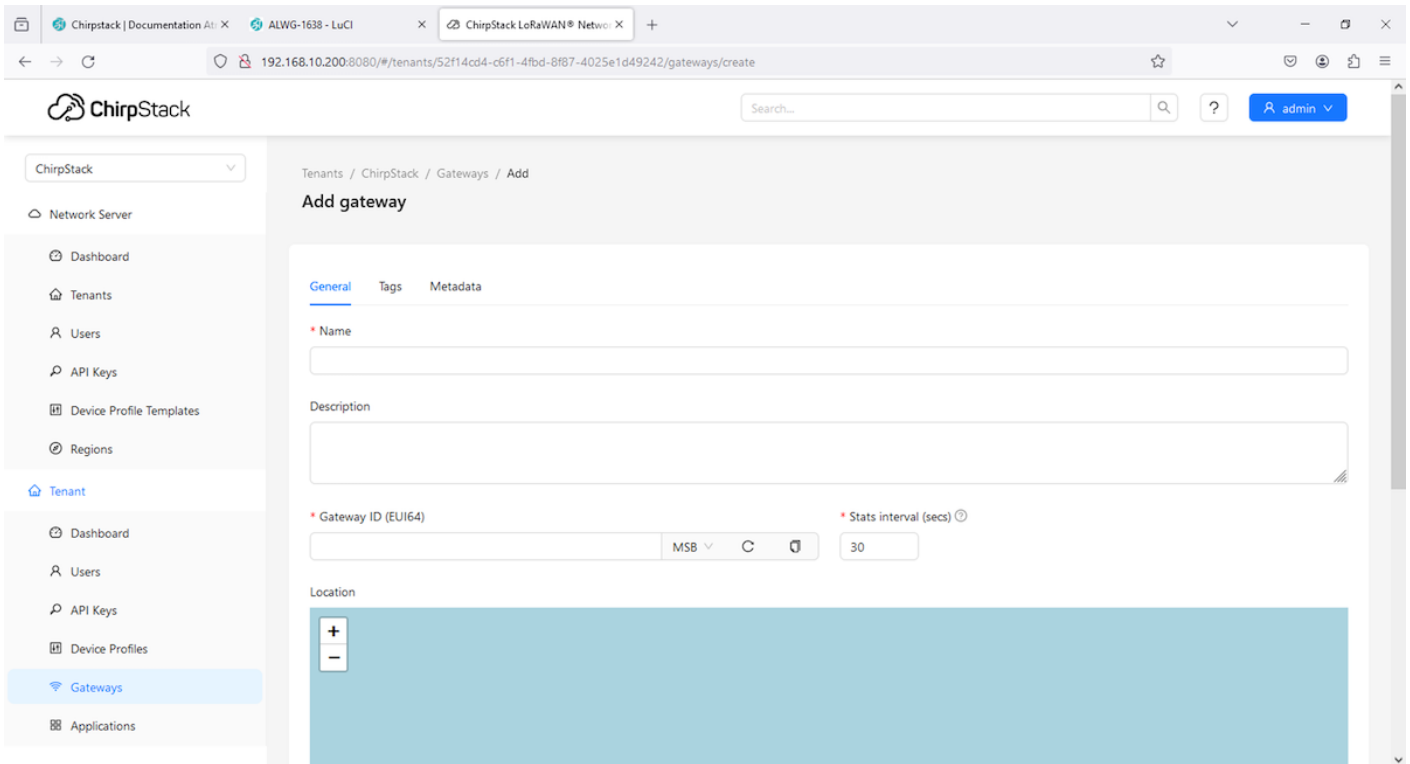

You can add data as per need and **Submit**.

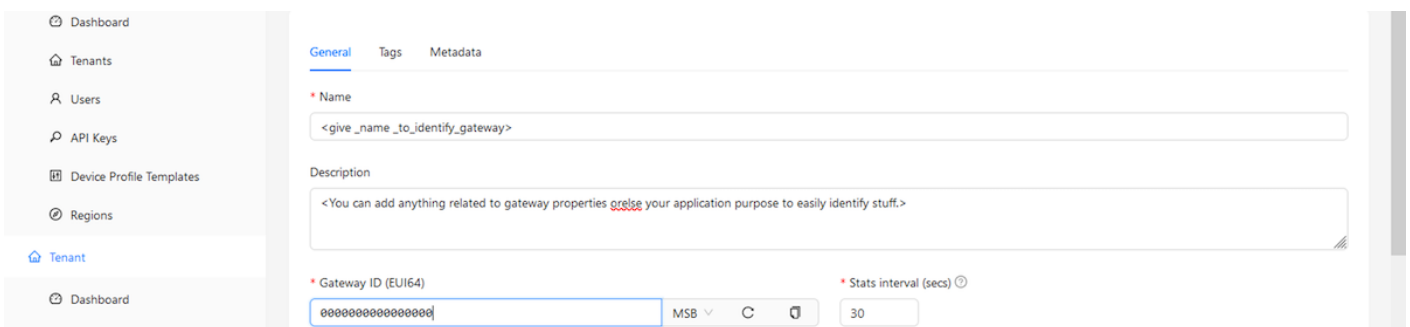

Makesure to findout Gateway ID from gateway webUI as shown in below image.

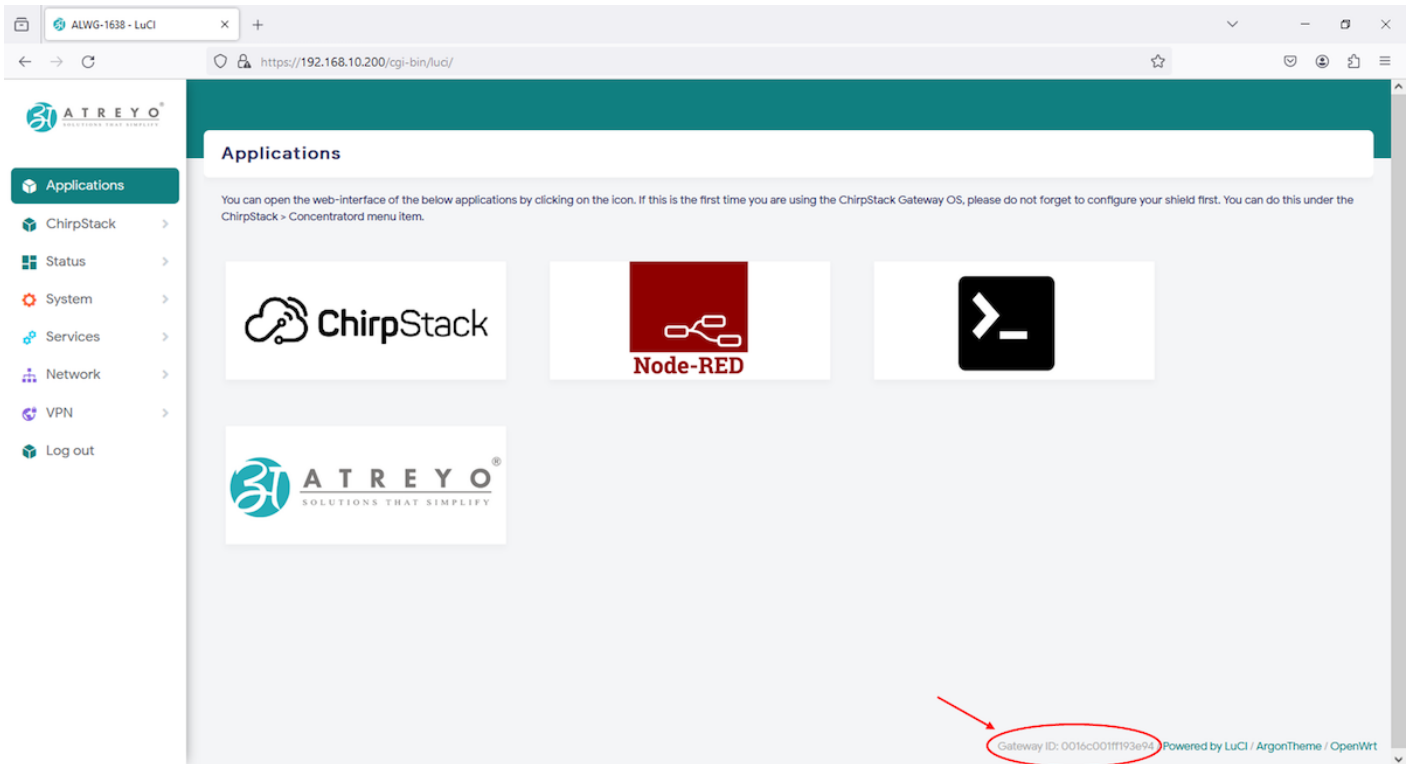

After submitting all the data pop-up at upper right side will shown to confirm that gateway has been added successfully. and it will open page where you can see Dashboard, it's configuration as well as option to see loraWAN frames.

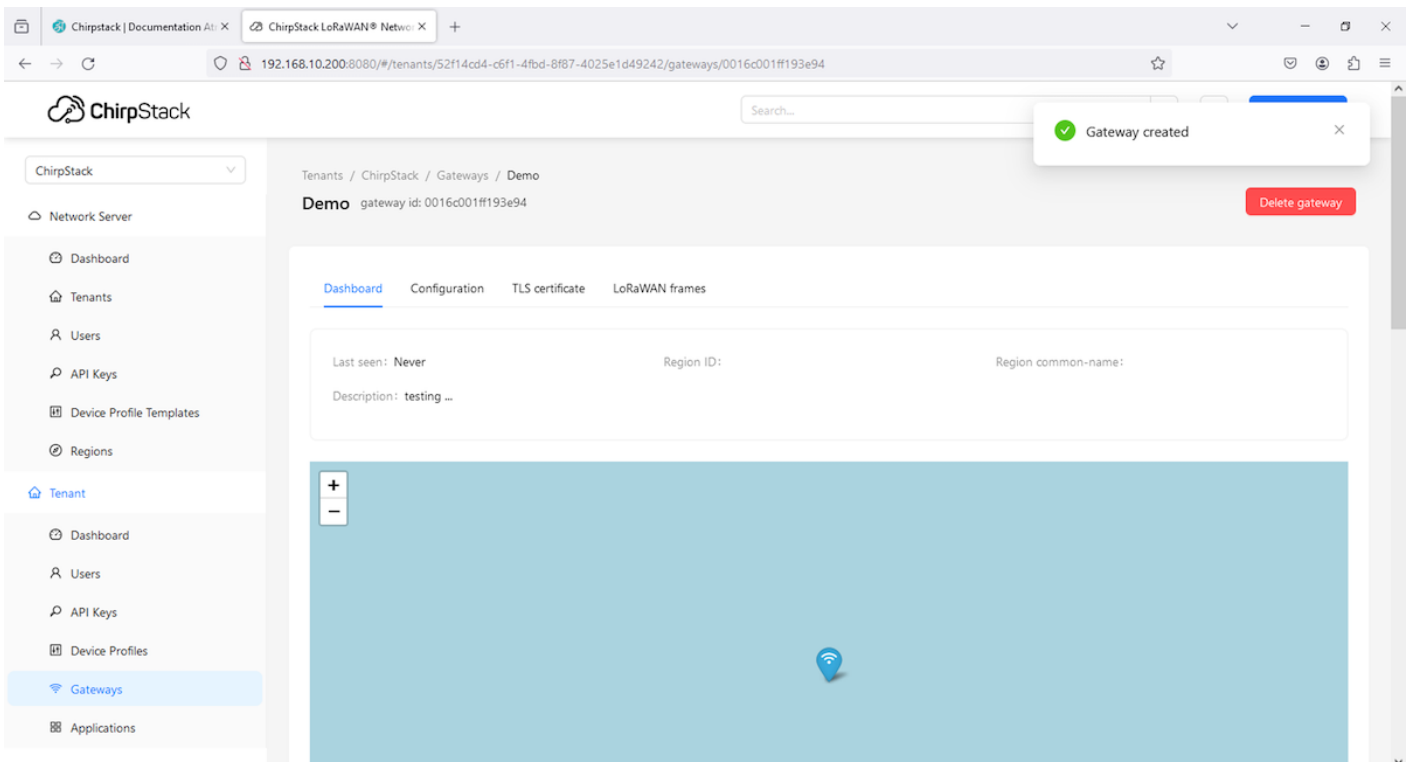

Last seen will change in a while as well as GPS will be fetched from gateway itself , also the metadata will be fetch from gateway.

Gateway status is also visible in Dashboard section as well as in Gateway section.

ALWG-1638 - LuCI | ChirpStack LoRaWAN® Netwo... X

192.168.10.200:8080/#/tenants/52f14cd4-c6f1-4fbd-8f87-4025e1d49242

ChirpStack

Search... ? admin

Tenants / ChirpStack

ChirpStack tenant id: 52f14cd4-c6f1-4fbd-8f87-4025e1d49242 Delete tenant

Dashboard Configuration

Active devices

No data

Active gateways

Never seen Offline Online

Device data-rate usage

No data

ChirpStack

Search... ? admin

Tenants / ChirpStack / Gateways

Gateways Add gateway Selected gateways

<input type="checkbox"/>	Last seen	Gateway ID	Name	Region ID	Region common-name
<input type="checkbox"/> Online	2024-04-02 11:46:39	0016c001f193e94	Demo	in865	IN865

< 1 > 10 / page

Click on Gateway ID to open Gateway ... (last seen and GPS has been updated after a while).

ChirpStack

Search... ? admin

Tenants / ChirpStack / Gateways / Demo

Demo gateway id: 0016c001f193e94 Delete gateway

Dashboard Configuration TLS certificate LoRaWAN frames

Last seen: 2024-04-02 11:38:29 Region ID: in865 Region common-name: IN865

Description: testing ...

To change configuration or edit anything got to Configuration tab, you can add tag for easy traceability in Tag tab under Configuration tab as well as gateway metadata will be fetched as shown below.

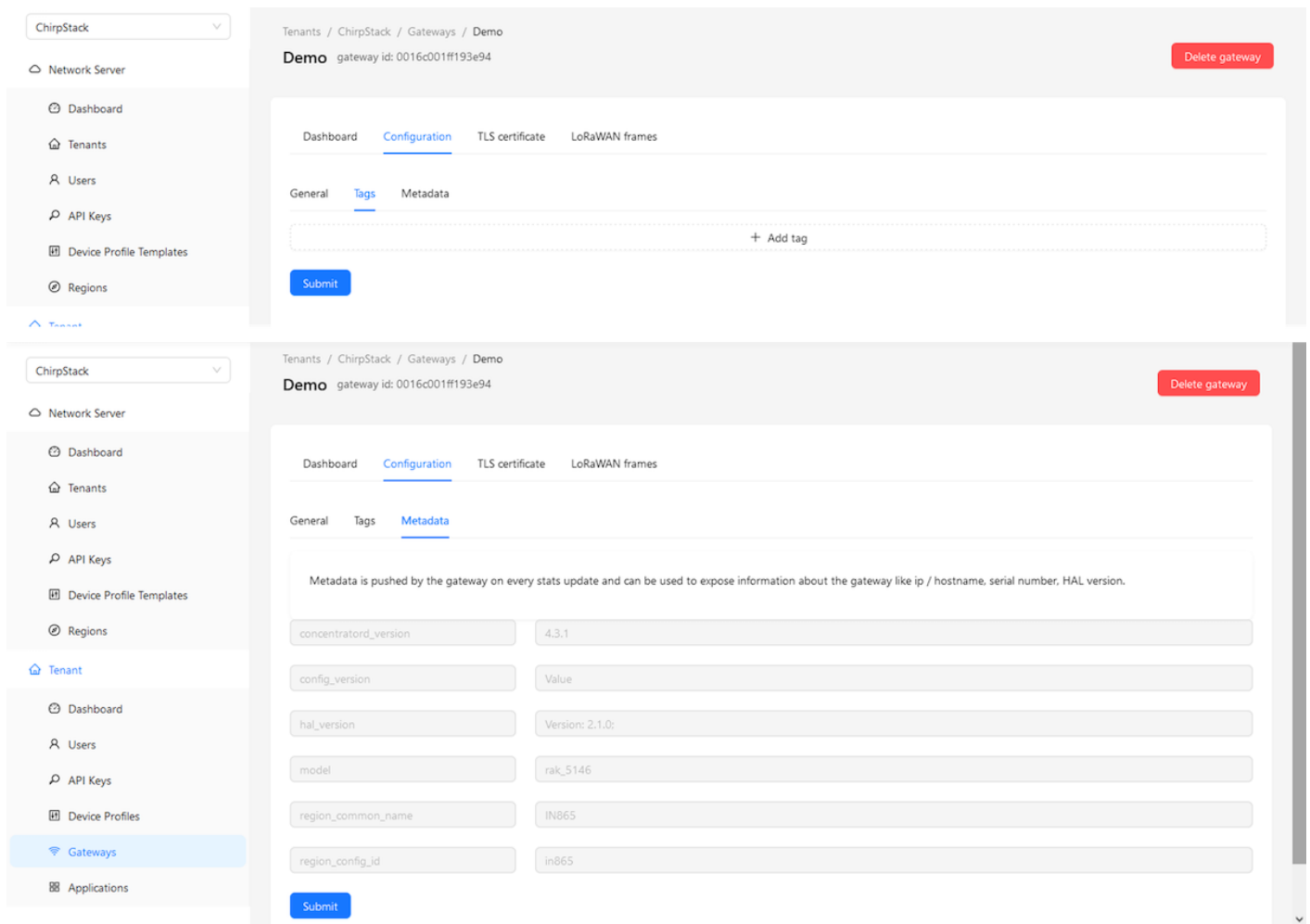

In TLS certificate tab you can generate TLS certificate for specific application.

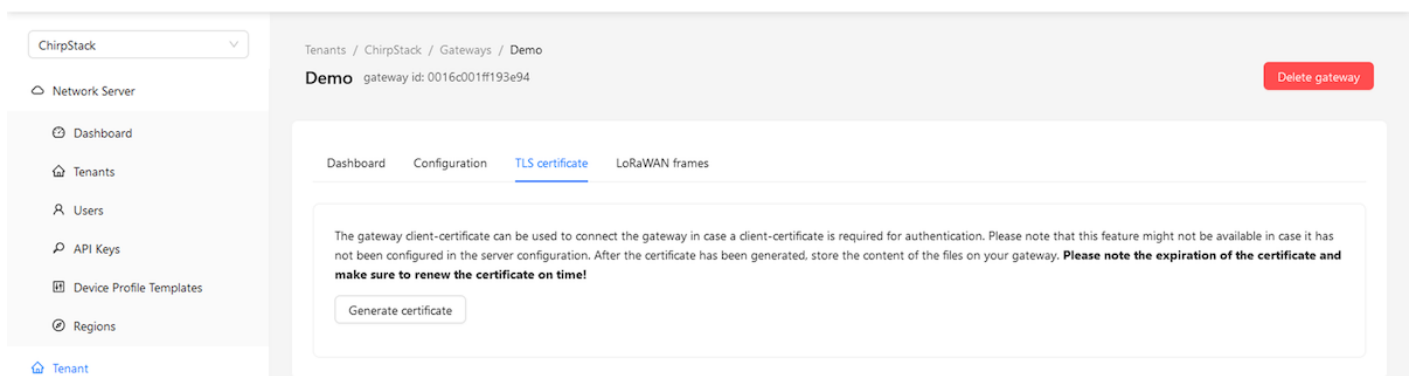

Once can download by clicking on **Download** button or open another sidebar to view event by clicking on event.

ChirpStack

Tenants / ChirpStack / Gateways / Demo

Demo gateway id: 0016c001ff193e94 Delete gateway

Dashboard Configuration TLS certificate LoRaWAN frames

Download

2024-04-01 18:51:22	UnconfirmedDataUp	DevAddr: 01cae33b
2024-04-01 18:50:50	UnconfirmedDataUp	DevAddr: 005d7efe

ChirpStack

Tenants / ChirpStack / Gateways / Demo

Demo gateway id: 0016c001ff193e94 Delete gateway

Dashboard Configuration TLS certificate LoRaWAN frames

Download

2024-04-01 18:51:22	UnconfirmedDataUp	DevAddr: 01cae33b
2024-04-01 18:50:50	UnconfirmedDataUp	DevAddr: 005d7efe
2024-04-01 18:50:08	UnconfirmedDataUp	DevAddr: 0067fdd9
2024-04-01 18:50:00	UnconfirmedDataUp	DevAddr: 01447ec8
2024-04-01 18:49:41	UnconfirmedDataUp	DevAddr: 01cae33b

Gateway | Documentation Atr... ChirpStack LoRaWAN® Netwo... +

192.168.10.200:8080/#/tenants/52f14cd4-c5f1-4fbd-8f87-4025e1d49242/gateways/0016c001ff193e94/frames

ChirpStack

Tenants / ChirpStack / Gateways / Demo

Demo gateway id: 0016c001ff193e94

Dashboard Configuration TLS certificate LoRaWAN frames

2024-04-01 18:51:22	UnconfirmedDataUp	DevAddr: 01cae33b
2024-04-01 18:50:50	UnconfirmedDataUp	DevAddr: 005d7efe
2024-04-01 18:50:08	UnconfirmedDataUp	DevAddr: 0067fdd9
2024-04-01 18:50:00	UnconfirmedDataUp	DevAddr: 01447ec8
2024-04-01 18:49:41	UnconfirmedDataUp	DevAddr: 01cae33b
2024-04-01 18:49:40	UnconfirmedDataUp	DevAddr: 00603b76
2024-04-01 18:49:27	UnconfirmedDataUp	DevAddr: 00603b76

```

phy_payload: {} 3 keys
  mhdr: {} 2 keys
    m_type: "UnconfirmedDataUp"
    major: "LoRaWANR1"
  mic: {} 4 items
    0: 149
    1: 161
    2: 130
    3: 25
  payload: {} 3 keys
    f_port: 9
    fhdr: {} 4 keys
      devaddr: "01cae33b"
      f_cnt: 45
      f_ctrl: {} 6 keys
        ack: false
        adr: true
        adr_ack_req: false
        class_b: false
        f_opts_len: 0
        f_pending: false
        f_opts: {} 0 items
      frm_payload: "d662431b3430d5d18795ca460bd3f4d8433083ab8ca5b8a46bddaee28b
bfc1eb017989057a43b23ce813c7ea69cd6489ca36"
    rx_info: {} 1 item
      0: {} 7 keys
        context: "UcYm9Q=="
        crcStatus: "CRC_OK"
        gatewayId: "0016c001ff193e94"
        metadata: {} 2 keys
          region_common_name: "IN865"
          region_config_id: "in865"
        rssi: -113
        snr: 1.5
        uplinkId: 933966086
  
```

Node-RED

NodRED functionality is pre-installed and it has been hosted on **1880 port**.

To access NodeRED use icon in **Application** section or open browser and hit "**<gateway_IP>:1880**"

New tab will open and and it might pop-up for user/pass if you are using it either first time or after long.

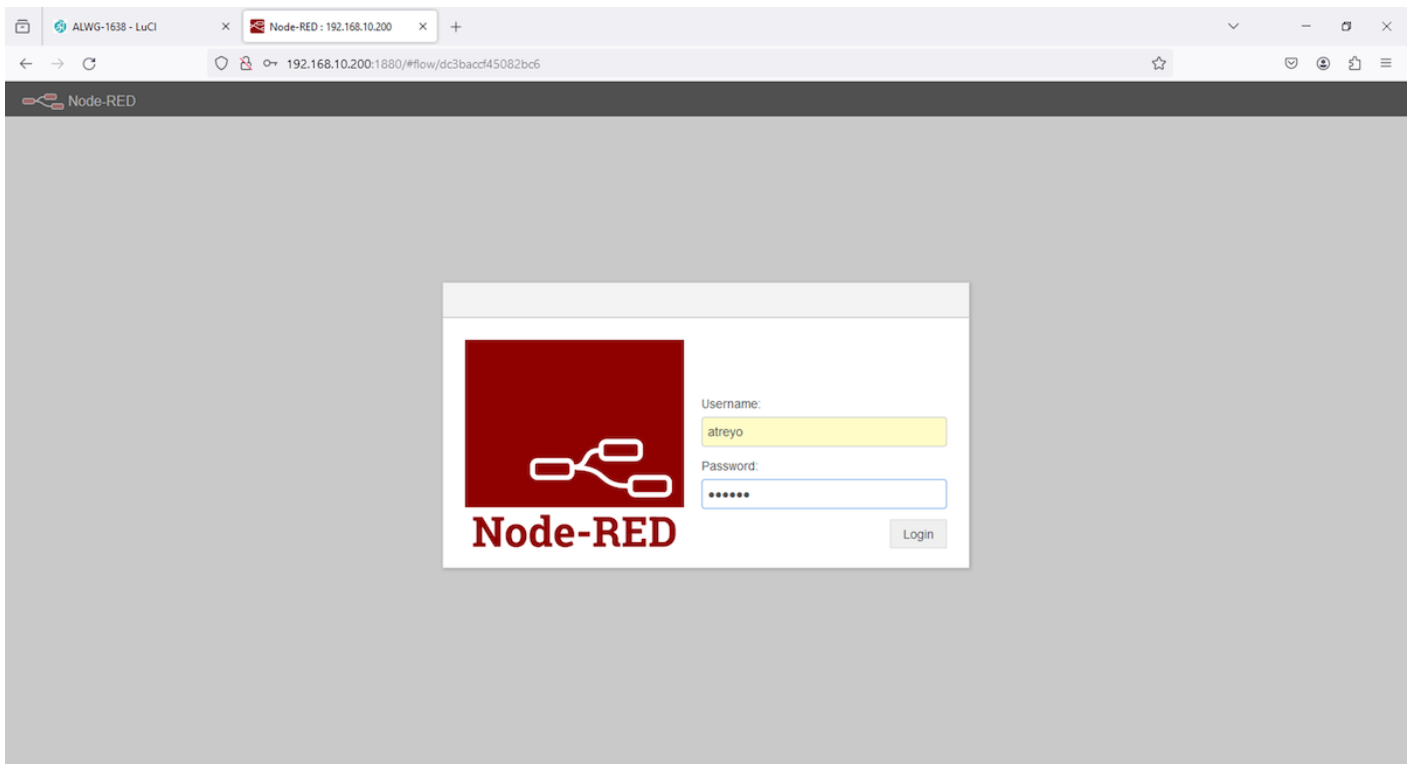

Credentials : user/pass --> **atreyo/atreyo**

After login in either you will have blank flow or any example flow saved by atreyo testing team.

1.

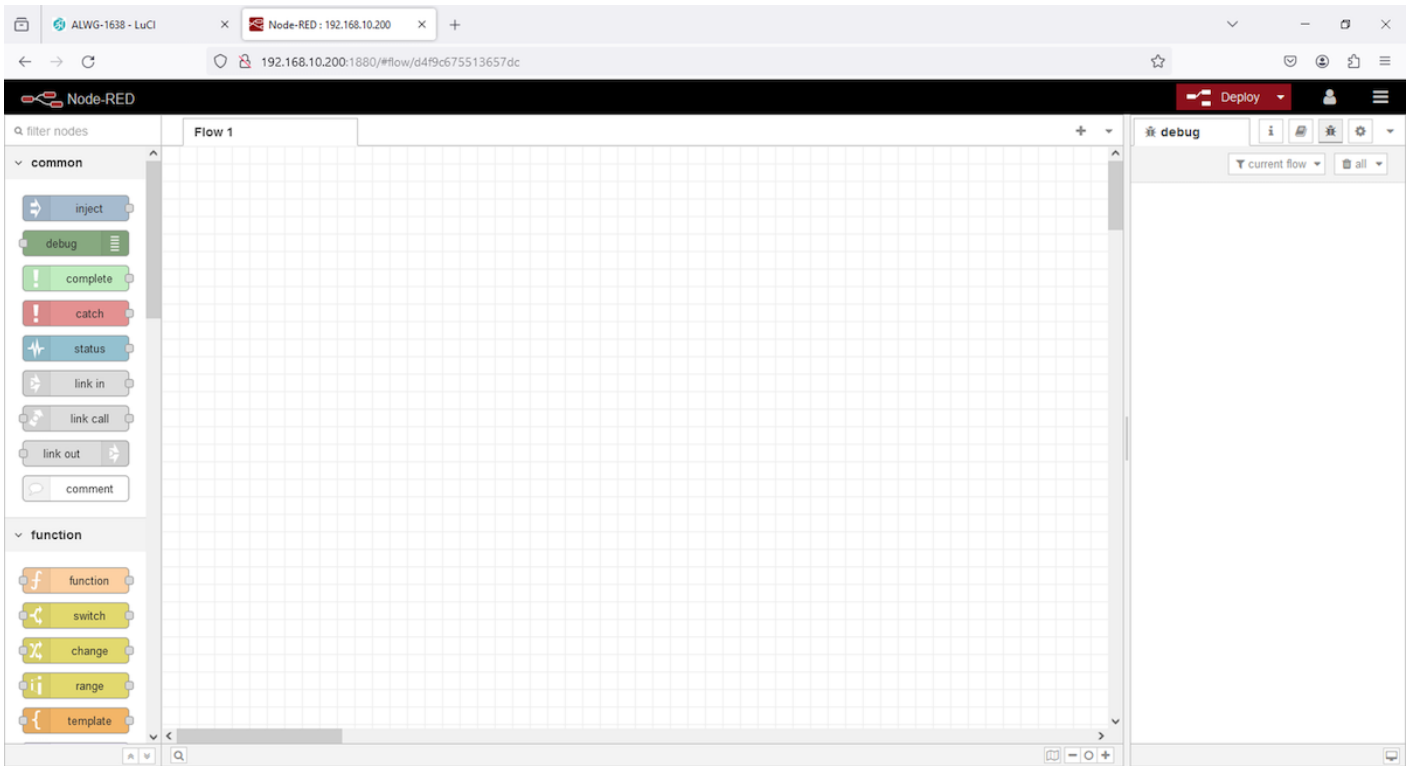

2.

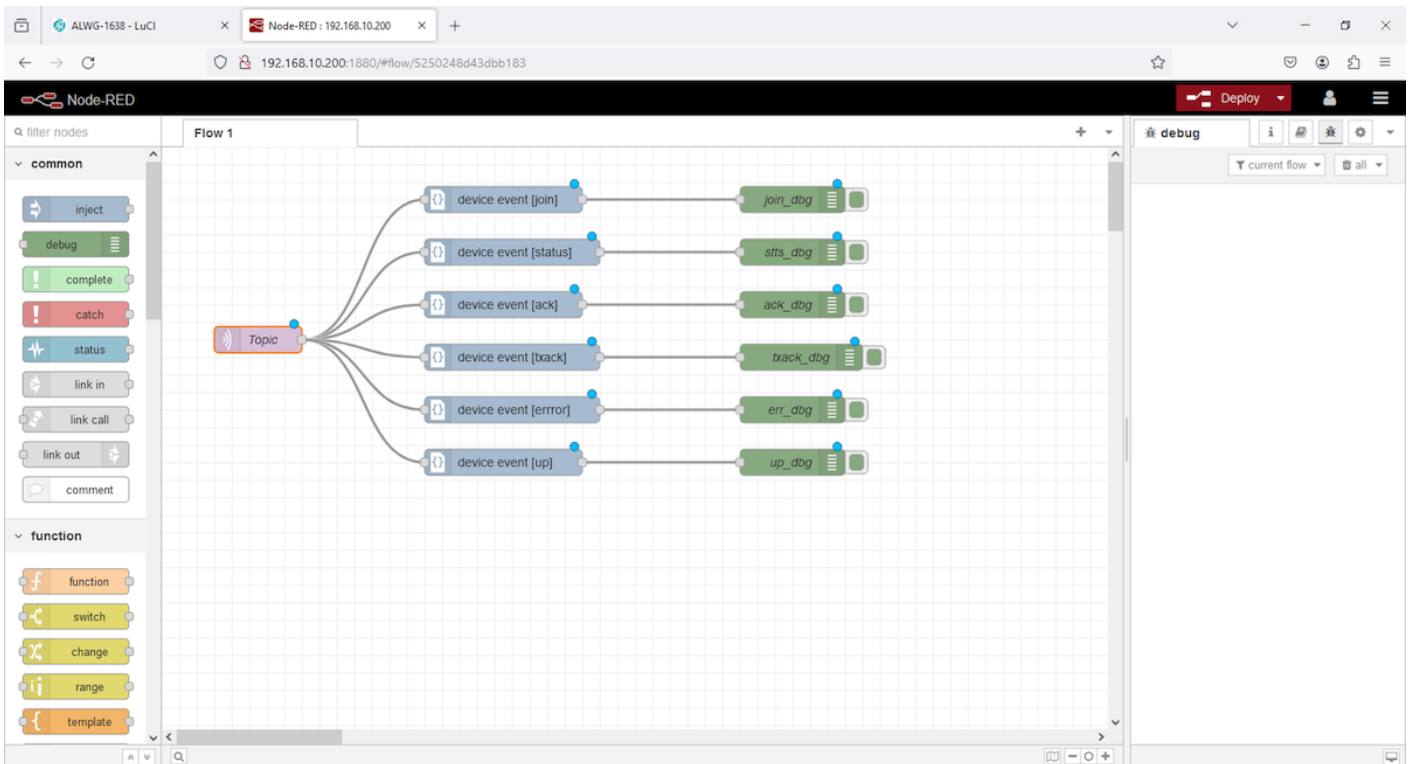

Above example flow is designed to fetch events of end devices, this flow will provide join, status, uplink, etc, events in debug.

To retrieve data from events one should write function in NodeRED, then data can be send to external platforms.

Use cases/ Examples

Application

- City and Industry LoraWAN applications
- Smart Street Light, Energy meters, water meters, and other meter applications
-

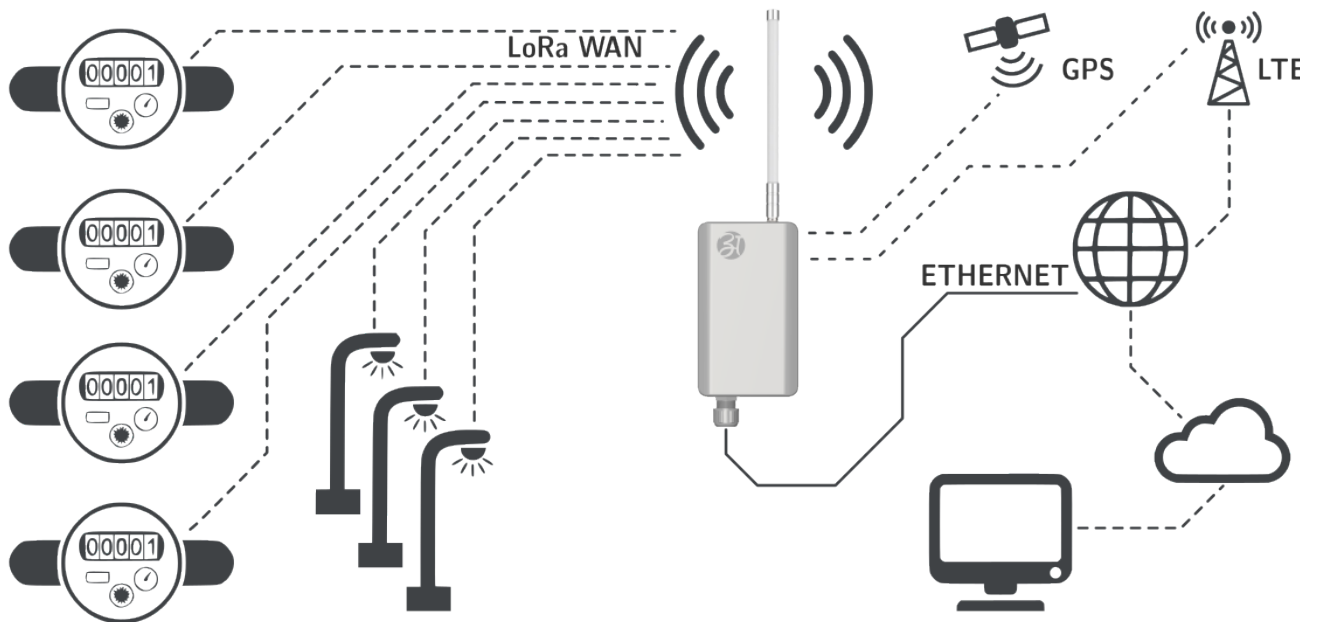

Firmware releases

The Gateway works on the OpenWRT operating system. The operating system is specially prepared and compiled for hardware. So when it is booted up, it is ready for use. In addition to the pre-installed application, we provide our own repository of free apps compiled for this Gateway. We update the system regularly to keep the latest version. You can check the latest releases here.

OpenWRT system	ChirpStack	Kernel version	Compilation date
23.05	4.3.0	5.10.146	

Safety information

Operating environment

- The device is designed to be installed in clean, dust-free and insect-free places
- Operating temperature: -25 ~ 65°C (-13 ~ 149°F).
- Humidity range is 10% to 95% (non-condensing). Use the device in a dry environment.
- Away from heat sources and direct sunlight.
- It must not be exposed to acid fumes, salts and other chemicals.
- The device must not be used in places where there is a risk of gas explosion.

Use in inappropriate conditions may damage the device or shorten its life.

Electrical and power supply safety

- The device is powered by PoE with a voltage in the range of 38-58V. Voltage up to 24V is considered safe. Be especially careful when supplying them with higher voltages.
- The device has the ability to control the output with the mains voltage of 160V. In this case, it is especially necessary to observe the safety rules during installation.
- Use only approved accessories
- Use the supplied power adapter or a good quality certified power adapter with the correct supply voltage range and sufficient power.
- Only use approved accessories like antenna etc.

Only a person with qualification and appropriate knowledge should install the device.

Malfunctioning and damaged device

- Do not disassemble the device.
- Only qualified personnel must service or repair the device or its accessories.
- If water or other liquid has got into the device, or if it looks mechanically damaged, do not connect the device, but take it to an authorized service center.

Radio frequency exposure

This device has been designed and manufactured not to exceed radio frequency energy emission limits set by regulatory agencies. To comply with RF exposure guidelines, the device must be used at least 20 cm away from a person's body. Failure to follow these instructions may result in

exceeding the applicable RF exposure limits. This only applies to models with a built-in LTE modem.

What to do and what not to do

- You are solely responsible for the use of the device and any consequences of its use.
- Do not store or use the device in harsh environments such as dust, gases, oils, chemical vapors and damp places.
- Do not throw the device and its accessories. Handle with care.
- The device heats up during operation. Ensure proper ventilation.
- If you need to dispose of your device, check your local regulations for recycling and disposal of electronics.
- Route power, Ethernet, and antenna cables properly so that they cannot be accidentally pulled out.
- The device should be used and kept away from small children.