

Configuration Manual

Configuration

AMB-8I-4O is an I/O expander operating over Modbus RTU and IEC60870-5-101 protocol. The first DIP switch is used to switch between Modbus RTU and IEC modes. If it is in position 0, then the AMB is operating in Modbus RTU mode. If it is in position 1, then it works in the IEC protocol. As the two protocols have different functions, the DIP switch is also different. In IEC mode, the last DIP switch is used to change the operating mode from balanced/unbalanced. To save the DIP switch settings in the internal memory, the SAVE button must be pressed.

- [Configuration IEC60870](#)
- [Configuration Modbus](#)

Configuration IEC60870

DIP switch configuration

This is DIP switch functions diagram for Modbus RTU configuration. For enable IEC60870 protocol 1 switch should be in ON position.

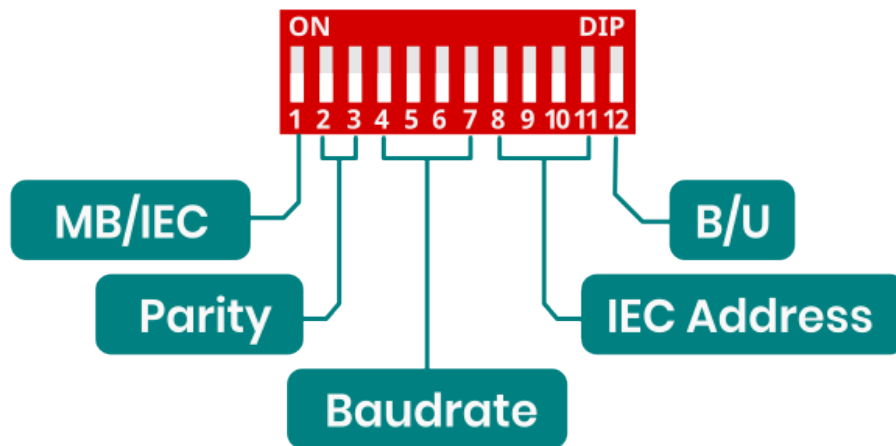

Parity configuration

Parity configuration for both Modbus and IEC.

Parity	Function
00	NONE
01	ODD
10	EVEN
11	NONE

Baudrate configuration

Baudrate configuration for both Modbus and IEC

Switch	Baudrate
0000	9600

Switch	Baudrate
0001	1200
0010	2400
0011	4800
0100	14400
0101	19200
0110	28800
0111	38400
1000	57600
1001	76800
1010	115200
1011	230400
1100	256000
1101	460800
1110	576000
1111	921600

Address configuration for IEC

Switch	Value	IEC Address
0000	0	1
0001	1	2
0010	2	3
0011	3	4
0100	4	5
0101	5	6
0110	6	7
0111	7	10

Switch	Value	IEC Address
1000	8	20
1001	9	30
1010	10	40
1011	11	50
1100	12	60
1101	13	70
1110	14	80
1111	15	90

EC60870-5-101 Implementation Guide

Protocol Overview

The device implements IEC60870-5-101 protocol with the following key functions:

Reading States (Interrogation)

- C_IC_NA_1 (100)
- Reading all inputs and outputs states
 - Inputs: 1000-1007
 - Outputs: 2000-2003

Controlling Outputs

- Function: C_SC_NA_1 (45)
- Purpose: Setting individual output states
- IOA range: 2000-2003
- Values: ON (1) / OFF (0)

Command Structure

General Interrogation Command

Type ID: 100 (C_IC_NA_1)
Qualifier: 20
Cause of Transmission: 6 (Activation)
Common Address: 1

Single Command (Output Control)

Type ID: 45 (C_SC_NA_1)
Cause of Transmission: 6 (Activation)
Common Address: 1
IOA: 2000-2003
Value: 0/1

SCADA system configuration

IEC60870-5-101 Protocol Configuration

- Common Address (ASDU): 1
- Frame format: FT1.2
- Link Layer Address: according to device configuration

I/O Points Configuration:

For inputs (8 channels):

- Type: Single Point Information (M_SP_NA_1)
- IOA addresses: 1000-1007
- Direction: Monitoring (read)

For outputs (4 channels):

- Type: Single Command (C_SC_NA_1)
- IOA addresses: 2000-2003
- Direction: Control (write)

Verification:

- Check if input states are correctly read (IOA 1000-1007)
- Confirm control operation for each output (IOA 2000-2003)
- Verify device responds to General Interrogation

Configuration Modbus

DIP switch configuration

This is DIP switch functions diagram for Modbus RTU configuration. For enable Modbus RTU protocol 1 switch should be in OFF position.

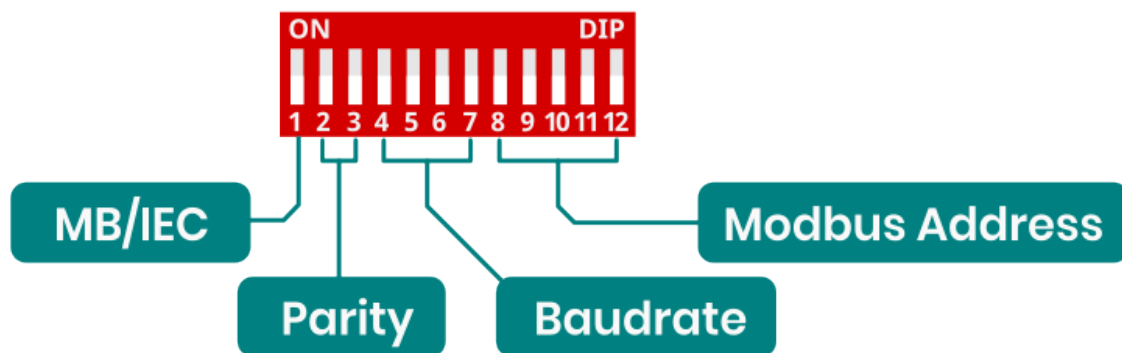

Baudrate configuration

Baudrate configuration for both Modbus and IEC

Switch	Baudrate
0000	9600
0001	1200
0010	2400
0011	4800
0100	14400
0101	19200
0110	28800
0111	38400
1000	57600
1001	76800

Switch	Baudrate
1010	115200
1011	230400
1100	256000
1101	460800
1110	576000
1111	921600

Address configuration for Modbus RTU

Switch	Value	Modbus Address
00000	0	1
00001	1	2
00010	2	3
00011	3	4
00100	4	5
00101	5	6
00110	6	7
00111	7	10
01000	8	20
01001	9	30
01010	10	40
01011	11	50
01100	12	60
01101	13	70

Switch	Value	Modbus Address
01110	14	80
01111	15	90
10000	16	100
10001	17	110
10010	18	120
10011	19	130
10100	20	140
10101	21	150
10110	22	160
10111	23	170
11000	24	180
11001	25	190
11010	26	200
11011	27	210
11100	28	220
11101	29	230
11110	30	240
11111	31	250

Address 1-247 → valid slave IDs for individual devices

Address 0 → reserved for broadcast messages; all slaves receive it but no one replies

Addresses 248-255 → reserved/unassigned (not permitted for standard device addressing)